

# GUHRING

- Taps for metric, metric-fine, UNC, UNF and PT threads
- For universal applications, stainless steel, cast iron and aluminium as well as for hard machining
- HSS-E-PM high-performance taps with new TiAlN-coating for improved chip evacuation and short chip generation

NEW

## Taps and fluteless taps to JIS standard

GUHRING - YOUR WORLD-WIDE PARTNER

# Your Perfect Choice

## JIS TAPS AND FLUTELESS TAPS MADE BY GUHRING



Green ring taps  
for universal applications  
M, MF, UNC, UNF and PT  
additional long versions



Cast iron and AISi taps  
universal thanks to IC  
for short chips in GG,  
Al and steel



Blue ring taps  
for stainless steel and  
acid-resistant steels  
M, MF



Hard machining taps  
for hardened steel  
(45-55 HRC)



High performance HSS-E-PM  
blue ring taps with new  
TiAlN-coating for improved  
chip evacuation



Fluteless taps  
for chipless threading in a  
wide range of materials



---

## Our expertise:

- › High quality cutting tools made in Germany
- › Optimal cutting materials and coatings
- › High precision grinding machines for finest tool geometries

---

## Your Benefits:

- › Long tool life
- › Best threading results
- › Optimal cost-performance-ratio

## Comparison yellow ring, green ring and blue ring

Conventional tapping  
with compensation chucks

Universal tapping with Synchro  
chucks or rigid collets



*Improved guidance with reduced relief angle for less rigid machines*

*Improved tool life, increased relief angle and back taper for stronger machines*

## Hard machining taps for hardened steel (45 - 55 HRC)

For tapping operations in materials with a tensile strength in excess of 1200 N/mm<sup>2</sup> we have developed a HSS-E-PM tap with TiCN coating.

The special design makes the process reliable production of threads in hard materials possible and provides excellent tool life.

Suitable for applications in the mold and die industry as well as for various machine or automotive components following heat treatment.

Recommended cutting speed  $v_c = 2 - 8$  m/min dependent on the hardness of the component.



# High performance HSS-E-PM blue ring taps with new TiAlN-coating for improved chip evacuation

Wide range of applications:

- stainless steel (martensitic / austenitic)
- steel materials max. 1300 N/m<sup>2</sup>
- copper-aluminum alloys and cast aluminium alloys

Thread systems M, MF and G

Improved chip evacuation thanks to special geometry and coating



*Thread chips can cause tool breakage*

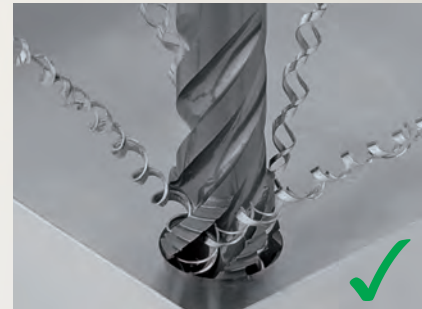

*Controlled chip evacuation with Guhring VA taps*

Significantly longer tool life and increased performance thanks to the combination of TiAlN wear-protection coating and WC/C slide coating

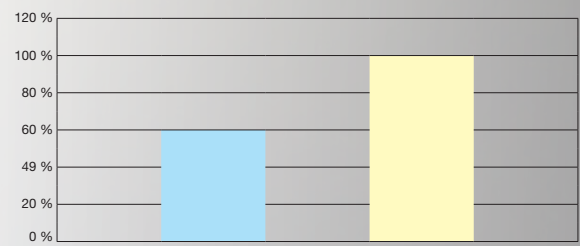

*Longer tool life thanks to more efficient coating*

## Universal taps with coolant ducts for short-chipping materials (GG, Al, steel)

Usually, with a tap the chips are evacuated from a blind hole via the spiral flutes. Cast iron, AlSi-alloys, brass and copper alloys are short-chipping materials. Straight-fluted taps are applied for such materials. With taps with coolant ducts, the coolant evacuates the short chips from the blind hole.

Our new straight-fluted M taps (Guhring no. 4448) and MF taps (Guhring no. 4472) with coolant ducts are especially suitable for short-chipping materials.

Evacuating long chips from steel components via the spiral flutes is an increasing problem.

Consequently, the aim is to produce short chips with straight-fluted taps and evacuate them from the blind hole with the cooling lubricant.

The tap with IC in the machine spindle achieves an improved tool life and surface quality of the thread.

Typical applications are the machining of gearboxes, cylinder blocks and heads, crankshafts, pump housings, hydraulic components etc.

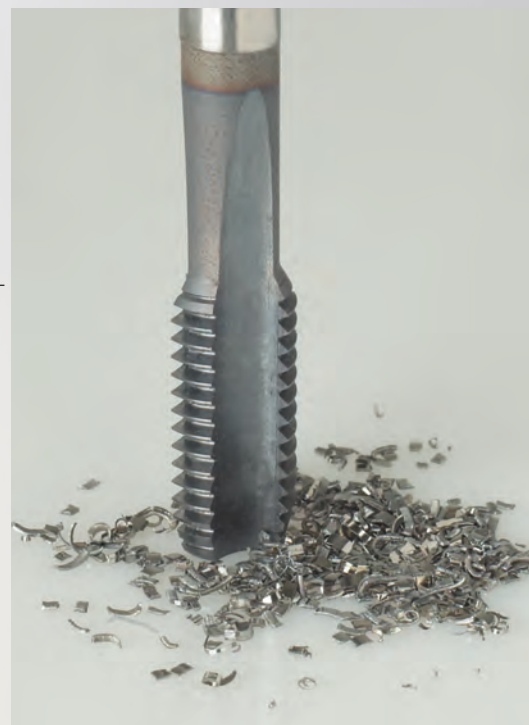

# JIS taps



Through holes



Blind holes

Thread depth  
Tool material  
Type/form  
Surface finish  
Cooling

		≤3xD									
		HSS-E									
		N/B	N/B	N/B	N R40/C	N R25/C	N R40/C	N R40/E	N R40/E	N R40/C	
		<input checked="" type="checkbox"/>	<input checked="" type="checkbox"/>	<input checked="" type="checkbox"/>	<input checked="" type="checkbox"/>	<input checked="" type="checkbox"/>	<input checked="" type="checkbox"/>	<input checked="" type="checkbox"/>	<input checked="" type="checkbox"/>	<input checked="" type="checkbox"/>	
				Long version 						Long version 	
		Guhring no.									
		Ø-range									
		Prices on page									
Thread type	Tolerance zone	Dim. to	1014 M2 – M20 p. 10	1015 M2 – M20 p. 10	4460 M3 – M20 p. 21	1012 M1.2 – M30 p. 15		1013 M2 – M20 p. 15	4432 M2 – M20 p. 17	4433 M2 – M20 p. 17	4462 M2 – M20 p. 21
M	Class 1 OH	JIS B 4430	4420 M2 – M20 p. 11	4421 M2 – M20 p. 11		4426 M2 – M20 p. 16		4427 M2 – M20 p. 16			
	Class 2 OH										
MF	Class 1 OH	JIS B 4430	4434 M6x0.75 – M20x1.5 p. 24	4435 M6x0.75 – M20x1.5 p. 24	4461 M6x0.75 – M20x1.5 p. 30	4438 M4x0.5 – M22x1.5 p. 27		4439 M6x0.75 – M20x1.5 p. 27			4463 M6x0.75 – M20x1.5 p. 30
UNC	Class 1 OH	~ JIS B 4430	4465 6-32 – 1-8 p. 33			4454 2-56 – 1-8 p. 33					
UNF	Class 1 OH	~ JIS B 4430	4455 6-40 – 1-12 p. 34			4457 6-40 – 1-12 p. 34					
PT	JIS 2	WN					4464 PT 1/16-28 – PT 1-11 p. 35				



Tools with colour-ring

# JIS fluteless taps



Through holes and blind holes

Tool material  
Type/form  
Surface finish  
Cooling

		HSS-E			Solid carbide
		N/C	N/C	N/C	N/C
		<input checked="" type="checkbox"/>	<input checked="" type="checkbox"/>	<input checked="" type="checkbox"/>	<input checked="" type="checkbox"/>
		with oil grooves			
		Guhring no.			
		Ø-range			
		Prices on page			
M	Class 1 RH		4442 M4 – M20 p. 36		
	Class 2 RH	1017 M1 – M20 p. 35	4443 M4 – M20 p. 36	4446 M5 – M20 p. 38	4447 M5 – M20 p. 38
MF	Class 1 RH		4444 M6x0,75 – M20x1,5 p. 37		
	Class 2 RH		4445 M6x0,75 – M20x1,5 p. 37		



Fluteless taps

Material examples

Structural steels

Free-cutting steels

Case hardened steels

Heat-treatable steels

Nitriding steels

Unalloyed case hardened steels

Unalloyed heat-treatable steels

Alloyed case hardened steels

Alloyed heat-treatable steels

Alloyed tool steels

High speed tool steels

Aluminium and Al-alloys

Al wrought alloys

Al cast alloys ≤ 10 % Si

Al cast alloys > 10 % Si

Cast iron

Spheroidal graphite iron

Malleable cast iron

Stainless- and acid-resistant steels  
sulphured, austenitic and martensitic

Brass, short-chipping

Brass, long-chipping

Plastics

Magnesium-alloys

Titanium and Ti-alloys

Ni-alloys

# JIS taps



≤3xD

HSS-E		HSS-E-PM		HSS-E		HSS-E-PM		HSS-E	HSS-E-PM	HSS-E	HSS-E-PM
VA/B	VA/B	N/B	N/B	VA R40/C	VA R40/C	N R45/C	N R45/C	N R40/C	H/D	GG/C	H/C
○	Ⓢ	○	Ⓐ	○	Ⓢ	○	Ⓐ	○	Ⓒ	○	Ⓒ
☒	☒	☒	☒	☒	☒	☒	☒	☒	☒	☒	ⓐ
<b>Guhring no.</b> O-range Prices on page											
4422 M2 – M20 p. 12	4423 M2 – M20 p. 12	4468 M2 – M20 p. 14	4470 M2 – M20 p. 14	4428 M2 – M20 p. 18	4429 M2 – M20 p. 18	4466 M2 – M20 p. 20	4449 M2 – M20 p. 20	4456 M2 – M20 p. 22	4453 M3 – M12 p. 22	4452 M2 – M20 p. 23	4448 M5 – M20 p. 23
4424 M2 – M20 p. 13	4425 M2 – M20 p. 13			4430 M2 – M20 p. 19	4431 M2 – M20 p. 19			4458 M6x0.75 – M20x1.5 p. 31	4459 M8x1 – M12x1.5 p. 31	4451 M6x0.75 – M20x1.5 p. 32	4472 M6x0.75 – M20x1.5 p. 32
4436 M6x0.75 – M20x1.5 p. 25	4437 M6x0.75 – M20x1.5 p. 25	4469 M6x0.75 – M20x1.5 p. 26	4471 M6x0.75 – M20x1.5 p. 26	4440 M6x0.75 – M20x1.5 p. 28	4441 M6x0.75 – M20x1.5 p. 28	4467 M6x0.75 – M20x1.5 p. 29	4450 M6x0.75 – M20x1.5 p. 29				

Universell	
Material no. to DIN EN 10 027	Abbreviation
<b>common structural steels</b>	
1.0035	S185 (St33)
1.0421	St 52.0
1.0067	RSt 37-1
1.0425	P265GH
<b>free-cutting steels</b>	
1.0711	9S20
1.0718	11SMnPb30
1.0727	46S20
1.0728	(60 S 20)
<b>case hardened steels</b>	
1.7131	16MnCr5
1.6523	21NiCrMo2-2
1.7321	20MoCr4
1.7325	25MoCr4
<b>unalloyed heat-treatable steels</b>	
1.0402	C22
1.1151	C22E
1.0503	C45
1.0601	C60
<b>nitriding steels</b>	
1.8504	34CrAl6
1.8507	34CrAlMo5
1.8509	41CrAlMo7
1.8515	31CrMo12
1.8550	34CrAlNi4
<b>spheroidal graphite iron</b>	
0.7040	EN-GJS-400-15
0.7060	EN-GJS-600-3

Acid./stainl. resist. steels	
Material no. to DIN EN 10 027	Abbreviation
<b>sulphured stainless steels</b>	
1.4005	X 12 CrS 13
1.4104	X 14 CrMo S 17
1.4105	X 6 CrMo S 17
1.4305	X 8CrNi S 18-9
<b>austenitic stainless steels</b>	
1.4300	X 12 CrNi 18-8
1.4301	X 5 CrNi 18-10
1.4541	X 6 CrNiTi 18-10
<b>martensitic stainless steels</b>	
1.4057	X 17 CrNi 16-2
1.4112	X 90 CrMoV 18
1.4006	X 12 Cr 13

General steels	
Material no. to DIN EN 10 027	Abbreviation
<b>Common structural steels</b>	
1.0035	S 185 (St 33)
1.0039	S 235 JRH
1.0036	S 235JRG1+CR
1.0060	E 335 (St 60-2)
<b>Free-cutting steels</b>	
1.0718	11SMnPb30
1.0721	10S20
1.0758	60SPb20
1.0726	35S20
<b>Case hardened steels</b>	
1.0401	(C 15)
1.7016	17 CR3
1.7131	16MnCr5
1.5919	15CrNi6
<b>Unalloyed heat-treatable steels</b>	
1.0402	C 22
1.1151	C22E (Ck 22)
1.0503	C 45
1.1191	C45E (Ck 45)

Cast materials	
Material no.	Abbreviation
<b>Cast iron</b>	
0.6015 (GG15)	EN-GJL-150
0.6025 (GG25)	EN-GJL-250
0.6040 (GG40)	EN-JLZ
<b>Spher. graph. iron mall. cast iron</b>	
0.7040 (GG40)	EN-GJS-400-15
0.7060 (GG60)	EN-GJS-600-3
0.8035	EN-GJMW-350-4
0.8135	EN-GJMB-350-10
<b>Compacted graphite iron</b>	
-	EN-GJV250
	EN-GJV350
	EN-GJV400
	EN-GJV500

- bright
- Ⓐ TiAlN
- Ⓢ TiN
- ☒ external coolant
- ⓐ internal radial coolant
- ⓐ internal axial coolant
- ⓐ through hole
- ⓐ blind hole

# Recommended cutting speeds

		HSS-E									
		N/B	N/B	N/B	N R40/C	N R25/C	N R40/C	N R40/E	N R40/E	N R40/E	
Thread		Ø-range on page									
M		10, 11	10, 11	21	15, 16		15, 16	17	17	21	
MF		24	24	30	27		27			30	
UNC		33			33						
UNF		34			34						
PT						35					
Material / ISO Material	Hardness N/mm <sup>2</sup>	Recommended cutting speed v <sub>c</sub> m/min									
<b>P</b>	Struct./free-cutt./unall. heat-treat./case hard. steels	≤ 800	10	15	10	10	10	15	10	15	10
	Free-cutting steels, unall. case hard. steels, nitr. steels	800 - 1 000	8	12	8	8	8	12	8	12	8
	Alloyed heat-treatable, tool and high speed steels	800 - 1200	6	8	6	6	6	8	6	8	6
<b>M</b>	Stainless steel - easy to machine / sulphured	≤ 750	6	8	6	6	6	8	6	8	6
	Stainless steel - moderately difficult to machine	750 - 950	6	8	6	6	6	8	6	6	6
<b>K</b>	Cast iron, grey cast iron, spher. graph./mall. cast iron		10	12	10	10	10	12	10	12	10
<b>N</b>	Aluminium, Al-wrought alloys, Al-alloys	≤ 6% Si	10	x	10	x	x	10	x	x	10
	Aluminium-cast alloys	≥ 6% Si	8	10	8	10	10	8	10	10	8
<b>S</b>	Titanium, Ti-alloys		x	2	x	x	x	2	x	2	x
	Ni-alloys		x	x	x	x	x	x	x	x	x
<b>H</b>	Hardened steels	45 - 55 HRC	x	x	x	x	x	x	x	x	x
	Hardened steels	55 - 62 HRC	x	x	x	x	x	x	x	x	x

		HSS-E	HSS-E	HSS-E	Solid carbide	
		N/C	N/C	N/C	N/C	
Thread		Ø-range on page				
M		35	36	38	38	
MF			37			
UNC						
UNF						
PT						
Material / ISO Material	Hardness N/mm <sup>2</sup>	Recommended cutting speed v <sub>c</sub> m/min				
<b>P</b>	Struct./free-cutt./unall. heat-treat./case hard. steels	≤ 800	10	12	15	25
	Free-cutting steels, unall. case hard. steels, nitr. steels	800 - 1 000	10	12	15	25
	Alloyed heat-treatable, tool and high speed steels	800 - 1200	8	10	12	20
<b>M</b>	Stainless steel - easy to machine / sulphured	≤ 750	4	8	10	15
	Stainless steel - moderately difficult to machine	750 - 950	4	8	10	15
<b>K</b>	Cast iron, grey cast iron, spher. graph./mall. cast iron		15	15	20	30
<b>N</b>	Aluminium, Al-wrought alloys, Al-alloys	≤ 6% Si	15	20	25	40
	Aluminium-cast alloys	≥ 6% Si	15	20	25	40
<b>S</b>	Titanium, Ti-alloys		4	4	6	15
	Ni-alloys		4	4	6	12
<b>H</b>	Hardened steels	45 - 55 HRC	x	x	x	x
	Hardened steels	55 - 62 HRC	x	x	x	x



## Recommended cutting speeds

HSS-E		HSS-E-PM		HSS-E		HSS-E-PM		HSS-E	HSS-E-PM	HSS-E	HSS-E-PM
VA/B	VA/B	N/B	N/B	VA R40/C	VA R40/C	N R45/C	N R45/C	N R40/C	H/D	GG/C	H/C
○ ☒ ○	● ☒ ○	○ ☒ ○	● ☒ ○	○ ☒ ○	● ☒ ○	○ ☒ ○	● ☒ ○	○ ☒ ○	● ☒	○ ☒ ○	● ☒ ○
Ø-range on page											
12, 13	12, 13	14	14	18, 19	18, 19	20	20	22, 31	22, 31	23, 32	23, 32
25	25	26	26	28	28	29	29				
Recommended cutting speed $v_c$ m/min											
10	15	12	20	10	15	12	20	10	x	x	x
8	12	12	18	8	12	12	18	4	x	x	15
6	8	8	15	6	8	8	15	x	x	x	12
8	10	10	12	8	10	10	12	x	x	x	x
8	10	10	12	8	10	10	12	x	x	x	x
10	12	12	20	10	12	12	20	6	15	20	25
10	x	12	20	10	x	12	20	10	x	x	x
8	10	12	20	8	10	12	20	x	15	15	25
x	2	x	2	x	2	x	2	x	x	x	x
x	x	x	2	x	x	x	2	x	x	x	x
x	x	x	x	x	x	x	x	x	4	x	x
x	x	x	x	x	x	x	x	x	x	x	x

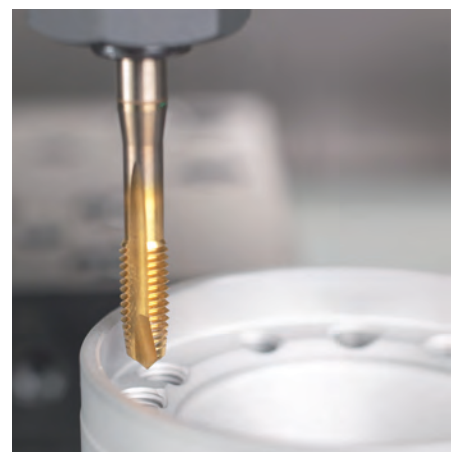

# JIS machine taps for ISO metric threads



**CLASS 1 OH**

Guhring no.

1014

Tool material

HSS-E

Surface finish

○

Type

N

Form

B

Discount group

203

Cutting direction

right-hand

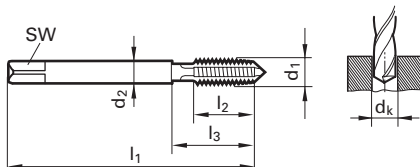

d1	P	Tolerance	d2	SW	dk	l1	l2	l3
	mm		mm		mm	mm	mm	mm
M 2	0.40	OH2	3.000	2.50	1.600	40.00	8.00	15.00
M 2.5	0.45	OH2	3.000	2.50	2.050	44.00	9.00	16.00
M 3	0.50	OH2	4.000	3.20	2.500	46.00	10.00	19.00
M 4	0.70	OH2	5.000	4.00	3.300	52.00	12.00	20.00
M 5	0.80	OH2	5.500	4.50	4.200	60.00	14.00	24.00
M 6	1.00	OH2	6.000	4.50	5.000	62.00	16.00	29.00
M 7	1.00	OH2	6.200	5.00	6.000	65.00	16.00	33.00
M 8	1.25	OH2	6.200	5.00	6.800	70.00	17.00	37.00
M 9	1.25	OH2	7.000	5.50	7.800	72.00	17.00	38.00
M10	1.50	OH2	7.000	5.50	8.500	75.00	20.00	41.00
M12	1.75	OH3	8.500	6.50	10.200	82.00	24.00	48.00
M14	2.00	OH3	10.500	8.00	12.000	88.00	26.00	48.00
M16	2.00	OH3	12.500	10.00	14.000	95.00	26.00	52.00
M18	2.50	OH4	14.000	11.00	15.500	100.00	30.00	55.00
M20	2.50	OH4	15.000	12.00	17.500	105.00	32.00	58.00

Availability



**CLASS 1 OH**

Guhring no.

1015

Tool material

HSS-E

Surface finish

Ⓢ

Type

N

Form

B

Discount group

203

Cutting direction

right-hand

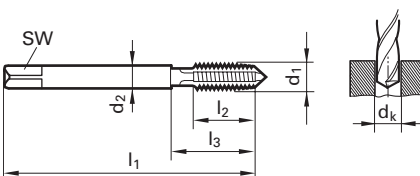

d1	P	Tolerance	d2	SW	dk	l1	l2	l3
	mm		mm		mm	mm	mm	mm
M 2	0.40	OH2	3.000	2.50	1.600	40.00	8.00	15.00
M 2.5	0.45	OH2	3.000	2.50	2.050	44.00	9.00	16.00
M 3	0.50	OH2	4.000	3.20	2.500	46.00	10.00	19.00
M 4	0.70	OH2	5.000	4.00	3.300	52.00	12.00	20.00
M 5	0.80	OH2	5.500	4.50	4.200	60.00	14.00	24.00
M 6	1.00	OH2	6.000	4.50	5.000	62.00	16.00	29.00
M 7	1.00	OH2	6.200	5.00	6.000	65.00	16.00	33.00
M 8	1.25	OH2	6.200	5.00	6.800	70.00	17.00	37.00
M 9	1.25	OH2	7.000	5.50	7.800	72.00	17.00	38.00
M10	1.50	OH2	7.000	5.50	8.500	75.00	20.00	41.00
M12	1.75	OH3	8.500	6.50	10.200	82.00	24.00	48.00
M14	2.00	OH3	10.500	8.00	12.000	88.00	26.00	48.00
M16	2.00	OH3	12.500	10.00	14.000	95.00	26.00	52.00
M18	2.50	OH4	14.000	11.00	15.500	100.00	30.00	55.00
M20	2.50	OH4	15.000	12.00	17.500	105.00	32.00	58.00

Availability



# JIS machine taps for ISO metric threads



**CLASS 2  
OH**

**Guhring no.**

**4420**

**Tool material**

**HSS-E**

**Surface finish**

○

**Type**

**N**

**Form**

**B**

**Discount group**

**203**

**Cutting direction**

**right-hand**

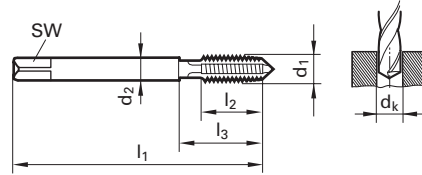

d1	P	Tolerance	d2	SW	dk	l1	l2	l3
	mm		mm		mm	mm	mm	mm
M 2	0.40	OH4	3.000	2.50	1.600	40.00	8.00	15.00
M 2.5	0.45	OH4	3.000	2.50	2.050	44.00	9.00	16.00
M 3	0.50	OH4	4.000	3.20	2.500	46.00	10.00	19.00
M 4	0.70	OH4	5.000	4.00	3.300	52.00	12.00	20.00
M 5	0.80	OH4	5.500	4.50	4.200	60.00	14.00	24.00
M 6	1.00	OH4	6.000	4.50	5.000	62.00	16.00	29.00
M 8	1.25	OH5	6.200	5.00	6.800	70.00	17.00	37.00
M10	1.50	OH5	7.000	5.50	8.500	75.00	20.00	41.00
M12	1.75	OH5	8.500	6.50	10.200	82.00	24.00	48.00
M14	2.00	OH5	10.500	8.00	12.000	88.00	26.00	48.00
M16	2.00	OH5	12.500	10.00	14.000	95.00	26.00	52.00
M18	2.50	OH5	14.000	11.00	15.500	100.00	30.00	55.00
M20	2.50	OH5	15.000	12.00	17.500	105.00	32.00	58.00

Availability



**CLASS 2  
OH**

**Guhring no.**

**4421**

**Tool material**

**HSS-E**

**Surface finish**

Ⓢ

**Type**

**N**

**Form**

**B**

**Discount group**

**203**

**Cutting direction**

**right-hand**

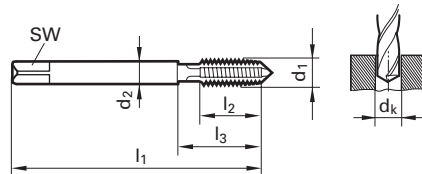

d1	P	Tolerance	d2	SW	dk	l1	l2	l3
	mm		mm		mm	mm	mm	mm
M 2	0.40	OH4	3.000	2.50	1.600	40.00	8.00	15.00
M 2.5	0.45	OH4	3.000	2.50	2.050	44.00	9.00	16.00
M 3	0.50	OH4	4.000	3.20	2.500	46.00	10.00	19.00
M 4	0.70	OH4	5.000	4.00	3.300	52.00	12.00	20.00
M 5	0.80	OH4	5.500	4.50	4.200	60.00	14.00	24.00
M 6	1.00	OH4	6.000	4.50	5.000	62.00	16.00	29.00
M 8	1.25	OH5	6.200	5.00	6.800	70.00	17.00	37.00
M10	1.50	OH5	7.000	5.50	8.500	75.00	20.00	41.00
M12	1.75	OH5	8.500	6.50	10.200	82.00	24.00	48.00
M14	2.00	OH5	10.500	8.00	12.000	88.00	26.00	48.00
M16	2.00	OH5	12.500	10.00	14.000	95.00	26.00	52.00
M18	2.50	OH5	14.000	11.00	15.500	100.00	30.00	55.00
M20	2.50	OH5	15.000	12.00	17.500	105.00	32.00	58.00

Availability



# JIS machine taps for ISO metric threads



**CLASS 1 OH**

**Guhring no.**

**4422**

**Tool material**

**HSS-E**

**Surface finish**

○

**Type**

**VA**

**Form**

**B**

**Discount group**

**203**

**Cutting direction**

**right-hand**

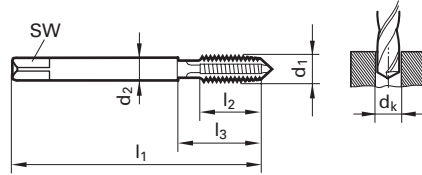

d1	P	Tolerance	d2	SW	dk	l1	l2	l3
	mm		mm		mm	mm	mm	mm
M 2	0.40	OH2	3.000	2.50	1.600	40.00	8.00	15.00
M 2.5	0.45	OH2	3.000	2.50	2.050	44.00	9.00	16.00
M 3	0.50	OH2	4.000	3.20	2.500	46.00	10.00	19.00
M 4	0.70	OH2	5.000	4.00	3.300	52.00	12.00	20.00
M 5	0.80	OH2	5.500	4.50	4.200	60.00	14.00	24.00
M 6	1.00	OH2	6.000	4.50	5.000	62.00	16.00	29.00
M 8	1.25	OH2	6.200	5.00	6.800	70.00	17.00	37.00
M10	1.50	OH2	7.000	5.50	8.500	75.00	20.00	41.00
M12	1.75	OH3	8.500	6.50	10.200	82.00	24.00	48.00
M14	2.00	OH3	10.500	8.00	12.000	88.00	26.00	48.00
M16	2.00	OH3	12.500	10.00	14.000	95.00	26.00	52.00
M18	2.50	OH4	14.000	11.00	15.500	100.00	30.00	55.00
M20	2.50	OH4	15.000	12.00	17.500	105.00	32.00	58.00

Availability
●
●
●
●
●
●
●
●
●
●
●
●
●
●



**CLASS 1 OH**

**Guhring no.**

**4423**

**Tool material**

**HSS-E**

**Surface finish**

Ⓢ

**Type**

**VA**

**Form**

**B**

**Discount group**

**203**

**Cutting direction**

**right-hand**

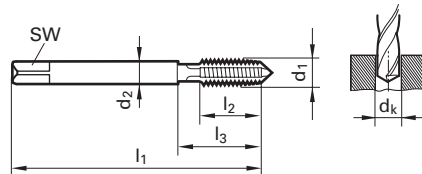

d1	P	Tolerance	d2	SW	dk	l1	l2	l3
	mm		mm		mm	mm	mm	mm
M 2	0.40	OH2	3.000	2.50	1.600	40.00	8.00	15.00
M 2.5	0.45	OH2	3.000	2.50	2.050	44.00	9.00	16.00
M 3	0.50	OH2	4.000	3.20	2.500	46.00	10.00	19.00
M 4	0.70	OH2	5.000	4.00	3.300	52.00	12.00	20.00
M 5	0.80	OH2	5.500	4.50	4.200	60.00	14.00	24.00
M 6	1.00	OH2	6.000	4.50	5.000	62.00	16.00	29.00
M 8	1.25	OH2	6.200	5.00	6.800	70.00	17.00	37.00
M10	1.50	OH2	7.000	5.50	8.500	75.00	20.00	41.00
M12	1.75	OH3	8.500	6.50	10.200	82.00	24.00	48.00
M14	2.00	OH3	10.500	8.00	12.000	88.00	26.00	48.00
M16	2.00	OH3	12.500	10.00	14.000	95.00	26.00	52.00
M18	2.50	OH4	14.000	11.00	15.500	100.00	30.00	55.00
M20	2.50	OH4	15.000	12.00	17.500	105.00	32.00	58.00

Availability
●
●
●
●
●
●
●
●
●
●
●
●
●
●

# JIS machine taps for ISO metric threads



**CLASS 2  
OH**

**Guhring no.**

**4424**

**Tool material**

**HSS-E**

**Surface finish**

○

**Type**

**VA**

**Form**

**B**

**Discount group**

**203**

**Cutting direction**

**right-hand**

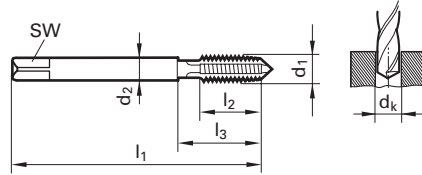

d1	P	Tolerance	d2	SW	dk	l1	l2	l3
	mm		mm		mm	mm	mm	mm
M 2	0.40	OH4	3.000	2.50	1.600	40.00	8.00	15.00
M 2.5	0.45	OH4	3.000	2.50	2.050	44.00	9.00	16.00
M 3	0.50	OH4	4.000	3.20	2.500	46.00	10.00	19.00
M 4	0.70	OH4	5.000	4.00	3.300	52.00	12.00	20.00
M 5	0.80	OH4	5.500	4.50	4.200	60.00	14.00	24.00
M 6	1.00	OH4	6.000	4.50	5.000	62.00	16.00	29.00
M 8	1.25	OH5	6.200	5.00	6.800	70.00	17.00	37.00
M10	1.50	OH5	7.000	5.50	8.500	75.00	20.00	41.00
M12	1.75	OH5	8.500	6.50	10.200	82.00	24.00	48.00
M14	2.00	OH5	10.500	8.00	12.000	88.00	26.00	48.00
M16	2.00	OH5	12.500	10.00	14.000	95.00	26.00	52.00
M18	2.50	OH5	14.000	11.00	15.500	100.00	30.00	55.00
M20	2.50	OH5	15.000	12.00	17.500	105.00	32.00	58.00

Availability
●
●
●
●
●
●
●
●
●
●
●
●
●
●



**CLASS 2  
OH**

**Guhring no.**

**4425**

**Tool material**

**HSS-E**

**Surface finish**

Ⓢ

**Type**

**VA**

**Form**

**B**

**Discount group**

**203**

**Cutting direction**

**right-hand**

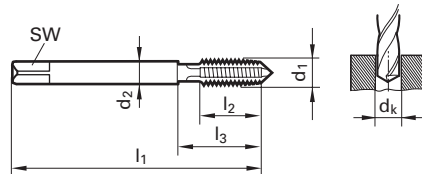

d1	P	Tolerance	d2	SW	dk	l1	l2	l3
	mm		mm		mm	mm	mm	mm
M 2	0.40	OH4	3.000	2.50	1.600	40.00	8.00	15.00
M 2.5	0.45	OH4	3.000	2.50	2.050	44.00	9.00	16.00
M 3	0.50	OH4	4.000	3.20	2.500	46.00	10.00	19.00
M 4	0.70	OH4	5.000	4.00	3.300	52.00	12.00	20.00
M 5	0.80	OH4	5.500	4.50	4.200	60.00	14.00	24.00
M 6	1.00	OH4	6.000	4.50	5.000	62.00	16.00	29.00
M 8	1.25	OH5	6.200	5.00	6.800	70.00	17.00	37.00
M10	1.50	OH5	7.000	5.50	8.500	75.00	20.00	41.00
M12	1.75	OH5	8.500	6.50	10.200	82.00	24.00	48.00
M14	2.00	OH5	10.500	8.00	12.000	88.00	26.00	48.00
M16	2.00	OH5	12.500	10.00	14.000	95.00	26.00	52.00
M18	2.50	OH5	14.000	11.00	15.500	100.00	30.00	55.00
M20	2.50	OH5	15.000	12.00	17.500	105.00	32.00	58.00

Availability
●
●
●
●
●
●
●
●
●
●
●
●
●
●

# JIS machine taps for ISO metric threads



**Guhring no.** 4468

**Tool material** HSS-E-PM

**Surface finish** ○

**Type** N

**Form** B

**Discount group** 203

**Cutting direction** right-hand

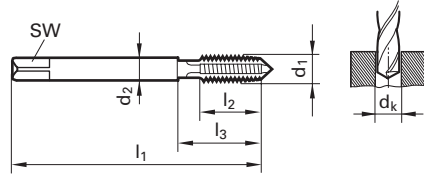

d1	P	Tolerance	d2	SW	dk	l1	l2	l3
	mm		mm		mm	mm	mm	mm
M2	0.40	OH1.5	3.000	2.50	1.600	40.00	8.00	15.00
M2.5	0.45	OH2	3.000	2.50	2.050	44.00	9.00	16.00
M3	0.50	OH2	4.000	3.20	2.500	46.00	10.00	19.00
M4	0.70	OH3	5.000	4.00	3.300	52.00	12.00	20.00
M5	0.80	OH3	5.500	4.50	4.200	60.00	14.00	24.00
M6	1.00	OH2	6.000	4.50	5.000	62.00	16.00	29.00
M8	1.25	OH2	6.200	5.00	6.800	70.00	17.00	37.00
M10	1.50	OH2	7.000	5.50	8.500	75.00	20.00	41.00
M12	1.75	OH4	8.500	6.50	10.200	82.00	24.00	48.00
M16	2.00	OH4	12.500	10.00	14.000	95.00	26.00	52.00
M20	2.50	OH5	15.000	12.00	17.500	105.00	32.00	58.00

Availability



**Guhring no.** 4470

**Tool material** HSS-E-PM

**Surface finish** ○<sup>A</sup>

**Type** N

**Form** B

**Discount group** 203

**Cutting direction** right-hand

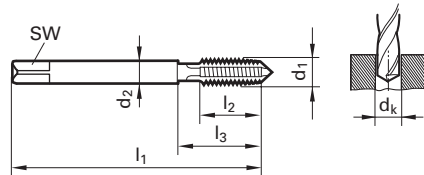

d1	P	Tolerance	d2	SW	dk	l1	l2	l3
	mm		mm		mm	mm	mm	mm
M2	0.40	OH1.5	3.000	2.50	1.600	40.00	8.00	15.00
M2.5	0.45	OH2	3.000	2.50	2.050	44.00	9.00	16.00
M3	0.50	OH2	4.000	3.20	2.500	46.00	10.00	19.00
M4	0.70	OH3	5.000	4.00	3.300	52.00	12.00	20.00
M5	0.80	OH3	5.500	4.50	4.200	60.00	14.00	24.00
M6	1.00	OH2	6.000	4.50	5.000	62.00	16.00	29.00
M8	1.25	OH2	6.200	5.00	6.800	70.00	17.00	37.00
M10	1.50	OH2	7.000	5.50	8.500	75.00	20.00	41.00
M12	1.75	OH4	8.500	6.50	10.200	82.00	24.00	48.00
M14	2.00	OH4	10.500	8.00	12.000	88.00	26.00	48.00
M16	2.00	OH4	12.500	10.00	14.000	95.00	26.00	52.00
M18	2.50	OH5	14.000	11.00	15.500	100.00	30.00	55.00
M20	2.50	OH5	15.000	12.00	17.500	105.00	32.00	58.00

Availability



## JIS machine taps for ISO metric threads



**CLASS 1  
OH**

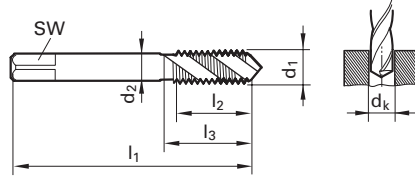

<b>Guhring no.</b>	<b>1012</b>
<b>Tool material</b>	<b>HSS-E</b>
<b>Surface finish</b>	○
<b>Type</b>	<b>N R40</b>
<b>Form</b>	<b>C</b>
<b>Discount group</b>	<b>203</b>
<b>Cutting direction</b>	<b>right-hand</b>



d1	P	Tolerance	d2	SW	dk	l1	l2	l3
mm	mm		mm		mm	mm	mm	mm
M1.2	0.25	OH1	3.000	2.50	0.950	36.00	4.80	9.00
M1.4	0.30	OH1	3.000	2.50	1.100	36.00	4.80	11.00
M1.6	0.35	OH1	3.000	2.50	1.250	36.00	6.40	13.00
M1.7	0.35	OH1	3.000	2.50	1.300	36.00	6.80	13.00
M2	0.40	OH1	3.000	2.50	1.600	40.00	4.50	15.00
M2.3	0.40	OH1	3.000	2.50	1.900	44.00	5.50	15.00
M2.5	0.45	OH1	3.000	2.50	2.050	44.00	5.00	16.00
M2.6	0.45	OH1	3.000	2.50	2.100	44.00	5.00	16.00
M3	0.50	OH2	4.000	3.20	2.500	46.00	6.00	19.00
M3.5	0.60	OH2	4.000	3.20	2.900	48.00	7.00	19.00
M4	0.70	OH2	5.000	4.00	3.300	52.00	7.50	20.00
M5	0.80	OH2	5.500	4.50	4.200	60.00	8.50	24.00
M6	1.00	OH2	6.000	4.50	5.000	62.00	11.00	29.00
M7	1.00	OH2	6.200	5.00	6.000	65.00	16.00	33.00
M8	1.25	OH2	6.200	5.00	6.800	70.00	14.00	37.00
M9	1.25	OH2	7.000	5.50	7.800	72.00	17.00	38.00
M10	1.50	OH2	7.000	5.50	8.500	75.00	16.00	41.00
M12	1.75	OH3	8.500	6.50	10.200	82.00	18.50	48.00
M14	2.00	OH3	10.500	8.00	12.000	88.00	20.00	48.00
M16	2.00	OH3	12.500	10.00	14.000	95.00	20.00	52.00
M18	2.50	OH4	14.000	11.00	15.500	100.00	25.00	55.00
M20	2.50	OH4	15.000	12.00	17.500	105.00	25.00	58.00
M22	2.50	OH4	17.000	13.00	19.500	115.00	27.00	63.00
M24	3.00	OH4	19.000	15.00	21.000	120.00	30.00	66.00
M30	3.500	OH4	23.000	17.00	16.500	135.00	35.00	74.00

Availability



**CLASS 1  
OH**

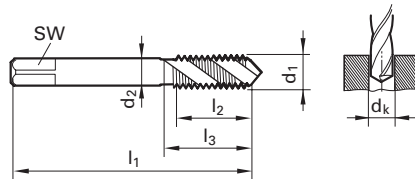

<b>Guhring no.</b>	<b>1013</b>
<b>Tool material</b>	<b>HSS-E</b>
<b>Surface finish</b>	Ⓢ
<b>Type</b>	<b>N R40</b>
<b>Form</b>	<b>C</b>
<b>Discount group</b>	<b>203</b>
<b>Cutting direction</b>	<b>right-hand</b>



d1	P	Tolerance	d2	SW	dk	l1	l2	l3
mm	mm		mm		mm	mm	mm	mm
M 2	0.40	OH2	3.000	2.50	1.600	40.00	4.50	15.00
M 2.5	0.45	OH2	3.000	2.50	2.050	44.00	5.00	16.00
M 3	0.50	OH2	4.000	3.20	2.500	46.00	6.00	19.00
M 4	0.70	OH2	5.000	4.00	3.300	52.00	7.50	20.00
M 5	0.80	OH2	5.500	4.50	4.200	60.00	8.50	24.00
M 6	1.00	OH2	6.000	4.50	5.000	62.00	11.00	29.00
M 7	1.00	OH2	6.200	5.00	6.000	65.00	16.00	33.00
M 8	1.25	OH2	6.200	5.00	6.800	70.00	14.00	37.00
M 9	1.25	OH2	7.000	5.50	7.800	72.00	17.00	38.00
M10	1.50	OH2	7.000	5.50	8.500	75.00	16.00	41.00
M12	1.75	OH3	8.500	6.50	10.200	82.00	18.50	48.00
M14	2.00	OH3	10.500	8.00	12.000	88.00	20.00	48.00
M16	2.00	OH3	12.500	10.00	14.000	95.00	20.00	52.00
M18	2.50	OH4	14.000	11.00	15.500	100.00	25.00	55.00
M20	2.50	OH4	15.000	12.00	17.500	105.00	25.00	58.00

Availability



# JIS machine taps for ISO metric threads



Blind holes

**CLASS 2  
OH**

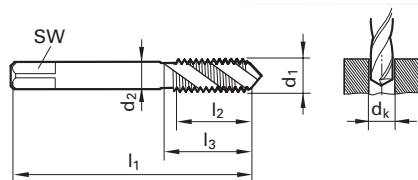

Guhring no.

4426

Tool material

HSS-E

Surface finish

○

Type

N R40

Form

C

Discount group

203

Cutting direction

right-hand

d1	P	Tolerance	d2	SW	dk	l1	l2	l3
	mm		mm		mm	mm	mm	mm
M 2	0.40	OH4	3.000	2.50	1.600	40.00	4.50	15.00
M 2.5	0.45	OH4	3.000	2.50	2.050	44.00	5.00	16.00
M 3	0.50	OH4	4.000	3.20	2.500	46.00	6.00	19.00
M 4	0.70	OH4	5.000	4.00	3.300	52.00	7.50	20.00
M 5	0.80	OH4	5.500	4.50	4.200	60.00	8.50	24.00
M 6	1.00	OH4	6.000	4.50	5.000	62.00	11.00	29.00
M 8	1.25	OH5	6.200	5.00	6.800	70.00	14.00	37.00
M10	1.50	OH5	7.000	5.50	8.500	75.00	16.00	41.00
M12	1.75	OH5	8.500	6.50	10.200	82.00	18.50	48.00
M14	2.00	OH5	10.500	8.00	12.000	88.00	20.00	48.00
M16	2.00	OH5	12.500	10.00	14.000	95.00	20.00	52.00
M18	2.50	OH5	14.000	11.00	15.500	100.00	25.00	55.00
M20	2.50	OH5	15.000	12.00	17.500	105.00	25.00	58.00

Availability



Blind holes

**CLASS 2  
OH**

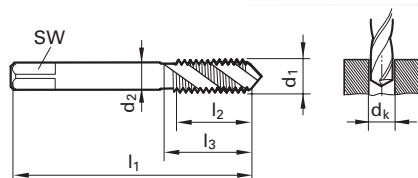

Guhring no.

4427

Tool material

HSS-E

Surface finish

Ⓢ

Type

N R40

Form

C

Discount group

203

Cutting direction

right-hand

d1	P	Tolerance	d2	SW	dk	l1	l2	l3
	mm		mm		mm	mm	mm	mm
M 2	0.40	OH4	3.000	2.50	1.600	40.00	4.50	15.00
M 2.5	0.45	OH4	3.000	2.50	2.050	44.00	5.00	16.00
M 3	0.50	OH4	4.000	3.20	2.500	46.00	6.00	19.00
M 4	0.70	OH4	5.000	4.00	3.300	52.00	7.50	20.00
M 5	0.80	OH4	5.500	4.50	4.200	60.00	8.50	24.00
M 6	1.00	OH4	6.000	4.50	5.000	62.00	11.00	29.00
M 8	1.25	OH5	6.200	5.00	6.800	70.00	14.00	37.00
M10	1.50	OH5	7.000	5.50	8.500	75.00	16.00	41.00
M12	1.75	OH5	8.500	6.50	10.200	82.00	18.50	48.00
M14	2.00	OH5	10.500	8.00	12.000	88.00	20.00	48.00
M16	2.00	OH5	12.500	10.00	14.000	95.00	20.00	52.00
M18	2.50	OH5	14.000	11.00	15.500	100.00	25.00	55.00
M20	2.50	OH5	15.000	12.00	17.500	105.00	25.00	58.00

Availability





# JIS machine taps for ISO metric threads



Blind holes

**CLASS 1  
OH**

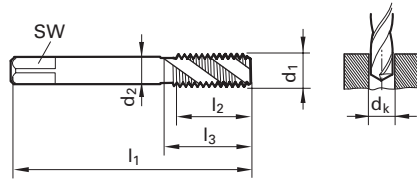

Guhring no.	4432
Tool material	HSS-E
Surface finish	○
Type	N R40
Form	E
Discount group	203
Cutting direction	right-hand



d1	P	Tolerance	d2	SW	dk	l1	l2	l3
	mm		mm		mm	mm	mm	mm
M 2	0.40	OH2	3.000	2.50	1.600	40.00	4.50	15.00
M 2.5	0.45	OH2	3.000	2.50	2.050	44.00	5.00	16.00
M 3	0.50	OH2	4.000	3.20	2.500	46.00	6.00	19.00
M 4	0.70	OH2	5.000	4.00	3.300	52.00	7.50	20.00
M 5	0.80	OH2	5.500	4.50	4.200	60.00	8.50	24.00
M 6	1.00	OH2	6.000	4.50	5.000	62.00	11.00	29.00
M 8	1.25	OH2	6.200	5.00	6.800	70.00	14.00	37.00
M10	1.50	OH2	7.000	5.50	8.500	75.00	16.00	41.00
M12	1.75	OH3	8.500	6.50	10.200	82.00	18.50	48.00
M14	2.00	OH3	10.500	8.00	12.000	88.00	20.00	48.00
M16	2.00	OH3	12.500	10.00	14.000	95.00	20.00	52.00
M18	2.50	OH4	14.000	11.00	15.500	100.00	25.00	55.00
M20	2.50	OH4	15.000	12.00	17.500	105.00	25.00	58.00

Availability
●
●
●
●
●
●
●
●
●
●
●
●
●
●



Blind holes

**CLASS 1  
OH**

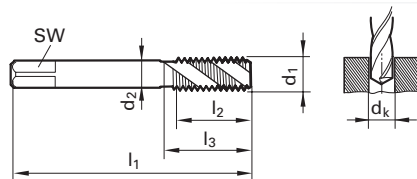

Guhring no.	4433
Tool material	HSS-E
Surface finish	Ⓢ
Type	N R40
Form	E
Discount group	203
Cutting direction	right-hand



d1	P	Tolerance	d2	SW	dk	l1	l2	l3
	mm		mm		mm	mm	mm	mm
M 2	0.40	OH2	3.000	2.50	1.600	40.00	8.00	15.00
M 2.5	0.45	OH2	3.000	2.50	2.050	44.00	9.00	16.00
M 3	0.50	OH2	4.000	3.20	2.500	46.00	10.00	19.00
M 4	0.70	OH2	5.000	4.00	3.300	52.00	12.00	20.00
M 5	0.80	OH2	5.500	4.50	4.200	60.00	14.00	24.00
M 6	1.00	OH2	6.000	4.50	5.000	62.00	16.00	29.00
M 8	1.25	OH2	6.200	5.00	6.800	70.00	17.00	37.00
M10	1.50	OH2	7.000	5.50	8.500	75.00	20.00	41.00
M12	1.75	OH3	8.500	6.50	10.200	82.00	24.00	48.00
M14	2.00	OH3	10.500	8.00	12.000	88.00	26.00	48.00
M16	2.00	OH3	12.500	10.00	14.000	95.00	26.00	52.00
M18	2.50	OH4	14.000	11.00	15.500	100.00	30.00	55.00
M20	2.50	OH4	15.000	12.00	17.500	105.00	32.00	58.00

Availability
●
●
●
●
●
●
●
●
●
●
●
●
●
●

# JIS machine taps for ISO metric threads



Blind holes

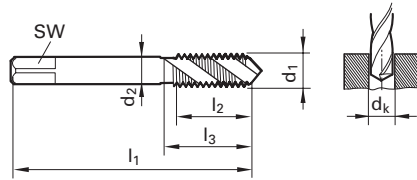

Guhring no.	4428
Tool material	HSS-E
Surface finish	○
Type	VA R40
Form	C
Discount group	203
Cutting direction	right-hand

d1	P	Tolerance	d2	SW	dk	l1	l2	l3
	mm		mm		mm	mm	mm	mm
M 2	0.40	OH2	3.000	2.50	1.600	40.00	4.50	15.00
M 2.5	0.45	OH2	3.000	2.50	2.050	44.00	5.00	16.00
M 3	0.50	OH2	4.000	3.20	2.500	46.00	6.00	19.00
M 4	0.70	OH2	5.000	4.00	3.300	52.00	7.50	20.00
M 5	0.80	OH2	5.500	4.50	4.200	60.00	8.50	24.00
M 6	1.00	OH2	6.000	4.50	5.000	62.00	11.00	29.00
M 8	1.25	OH2	6.200	5.00	6.800	70.00	14.00	37.00
M10	1.50	OH2	7.000	5.50	8.500	75.00	16.00	41.00
M12	1.75	OH3	8.500	6.50	10.200	82.00	18.50	48.00
M14	2.00	OH3	10.500	8.00	12.000	88.00	20.00	48.00
M16	2.00	OH3	12.500	10.00	14.000	95.00	20.00	52.00
M18	2.50	OH4	14.000	11.00	15.500	100.00	25.00	55.00
M20	2.50	OH4	15.000	12.00	17.500	105.00	25.00	58.00

Availability
●
●
●
●
●
●
●
●
●
●
●
●
●
●



Blind holes

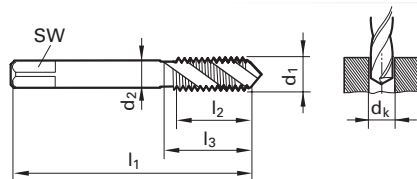

Guhring no.	4429
Tool material	HSS-E
Surface finish	Ⓢ
Type	VA R40
Form	C
Discount group	203
Cutting direction	right-hand

d1	P	Tolerance	d2	SW	dk	l1	l2	l3
	mm		mm		mm	mm	mm	mm
M 2	0.40	OH2	3.000	2.50	1.600	40.00	4.50	15.00
M 2.5	0.45	OH2	3.000	2.50	2.050	44.00	5.00	16.00
M 3	0.50	OH2	4.000	3.20	2.500	46.00	6.00	19.00
M 4	0.70	OH2	5.000	4.00	3.300	52.00	7.50	20.00
M 5	0.80	OH2	5.500	4.50	4.200	60.00	8.50	24.00
M 6	1.00	OH2	6.000	4.50	5.000	62.00	11.00	29.00
M 8	1.25	OH2	6.200	5.00	6.800	70.00	14.00	37.00
M10	1.50	OH2	7.000	5.50	8.500	75.00	16.00	41.00
M12	1.75	OH3	8.500	6.50	10.200	82.00	18.50	48.00
M14	2.00	OH3	10.500	8.00	12.000	88.00	20.00	48.00
M16	2.00	OH3	12.500	10.00	14.000	95.00	20.00	52.00
M18	2.50	OH4	14.000	11.00	15.500	100.00	25.00	55.00
M20	2.50	OH4	15.000	12.00	17.500	105.00	25.00	58.00

Availability
●
●
●
●
●
●
●
●
●
●
●
●
●
●

# JIS machine taps for ISO metric threads



Blind holes

**CLASS 2  
OH**

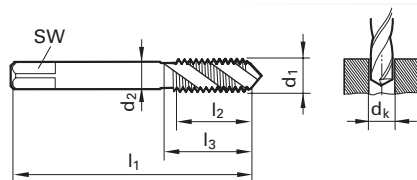

Guhring no.

4430

Tool material

HSS-E

Surface finish

○

Type

VA R40

Form

C

Discount group

203

Cutting direction

right-hand



d1	P	Tolerance	d2	SW	dk	l1	l2	l3
	mm		mm		mm	mm	mm	mm
M 2	0.40	OH4	3.000	2.50	1.600	40.00	4.50	15.00
M 2.5	0.45	OH4	3.000	2.50	2.050	44.00	5.00	16.00
M 3	0.50	OH4	4.000	3.20	2.500	46.00	6.00	19.00
M 4	0.70	OH4	5.000	4.00	3.300	52.00	7.50	20.00
M 5	0.80	OH4	5.500	4.50	4.200	60.00	8.50	24.00
M 6	1.00	OH4	6.000	4.50	5.000	62.00	11.00	29.00
M 8	1.25	OH5	6.200	5.00	6.800	70.00	14.00	37.00
M10	1.50	OH5	7.000	5.50	8.500	75.00	16.00	41.00
M12	1.75	OH5	8.500	6.50	10.200	82.00	18.50	48.00
M14	2.00	OH5	10.500	8.00	12.000	88.00	20.00	48.00
M16	2.00	OH5	12.500	10.00	14.000	95.00	20.00	52.00
M18	2.50	OH5	14.000	11.00	15.500	100.00	25.00	55.00
M20	2.50	OH5	15.000	12.00	17.500	105.00	25.00	58.00

Availability



Blind holes

**CLASS 2  
OH**

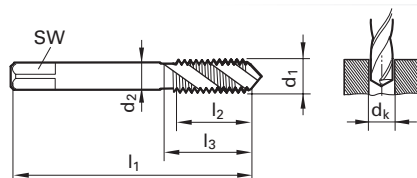

Guhring no.

4431

Tool material

HSS-E

Surface finish

Ⓢ

Type

VA R40

Form

C

Discount group

203

Cutting direction

right-hand



d1	P	Tolerance	d2	SW	dk	l1	l2	l3
	mm		mm		mm	mm	mm	mm
M 2	0.40	OH4	3.000	2.50	1.600	40.00	4.50	15.00
M 2.5	0.45	OH4	3.000	2.50	2.050	44.00	5.00	16.00
M 3	0.50	OH4	4.000	3.20	2.500	46.00	6.00	19.00
M 4	0.70	OH4	5.000	4.00	3.300	52.00	7.50	20.00
M 5	0.80	OH4	5.500	4.50	4.200	60.00	8.50	24.00
M 6	1.00	OH4	6.000	4.50	5.000	62.00	11.00	29.00
M 8	1.25	OH5	6.200	5.00	6.800	70.00	14.00	37.00
M10	1.50	OH5	7.000	5.50	8.500	75.00	16.00	41.00
M12	1.75	OH5	8.500	6.50	10.200	82.00	18.50	48.00
M14	2.00	OH5	10.500	8.00	12.000	88.00	20.00	48.00
M16	2.00	OH5	12.500	10.00	14.000	95.00	20.00	52.00
M18	2.50	OH5	14.000	11.00	15.500	100.00	25.00	55.00
M20	2.50	OH5	15.000	12.00	17.500	105.00	25.00	58.00

Availability



# JIS machine taps for ISO metric threads



Blind holes

**Guhring no.**

**4466**

**Tool material**

**HSS-E-PM**

**Surface finish**



**Type**

**N R40**

**Form**

**C**

**Discount group**

**203**

**Cutting direction**

**right-hand**

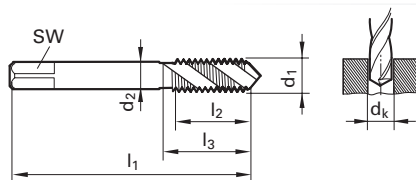

d1	P	Tolerance	d2	SW	dk	l1	l2	l3
	mm		mm		mm	mm	mm	mm
M2	0.40	OH1.5	3.000	2.50	1.600	40.00	8.00	15.00
M2.5	0.45	OH2	3.000	2.50	2.050	44.00	9.00	16.00
M3	0.50	OH2	4.000	3.20	2.500	46.00	10.00	19.00
M4	0.70	OH3	5.000	4.00	3.300	52.00	12.00	20.00
M5	0.80	OH3	5.500	4.50	4.200	60.00	14.00	24.00
M6	1.00	OH2	6.000	4.50	5.000	62.00	16.00	29.00
M8	1.25	OH2	6.200	5.00	6.800	70.00	17.00	37.00
M10	1.50	OH2	7.000	5.50	8.500	75.00	20.00	41.00
M12	1.75	OH4	8.500	6.50	10.200	82.00	24.00	48.00
M16	2.00	OH4	12.500	10.00	14.000	95.00	26.00	52.00
M20	2.50	OH5	15.000	12.00	17.500	105.00	32.00	58.00

Availability



**Guhring no.**

**4449**

**Tool material**

**HSS-E-PM**

**Surface finish**



**Type**

**N R40**

**Form**

**C**

**Discount group**

**203**

**Cutting direction**

**right-hand**

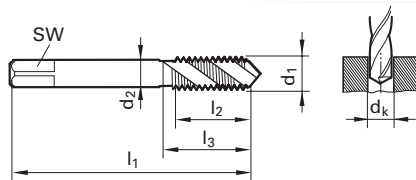

d1	P	Tolerance	d2	SW	dk	l1	l2	l3
	mm		mm		mm	mm	mm	mm
M2	0.40	OH1.5	3.000	2.50	1.600	40.00	8.00	15.00
M2.5	0.45	OH2	3.000	2.50	2.050	44.00	9.00	16.00
M3	0.50	OH2	4.000	3.20	2.500	46.00	10.00	19.00
M4	0.70	OH3	5.000	4.00	3.300	52.00	12.00	20.00
M5	0.80	OH3	5.500	4.50	4.200	60.00	14.00	24.00
M6	1.00	OH2	6.000	4.50	5.000	62.00	16.00	29.00
M8	1.25	OH2	6.200	5.00	6.800	70.00	17.00	37.00
M10	1.50	OH2	7.000	5.50	8.500	75.00	20.00	41.00
M12	1.75	OH4	8.500	6.50	10.200	82.00	24.00	48.00
M14	2.00	OH4	10.500	8.00	12.000	88.00	26.00	48.00
M16	2.00	OH4	12.500	10.00	14.000	95.00	26.00	52.00
M18	2.50	OH5	14.000	11.00	15.500	100.00	30.00	55.00
M20	2.50	OH5	15.000	12.00	17.500	105.00	32.00	58.00

Availability



# JIS machine taps with long shank for ISO metric threads



Through holes

**Guhring no.**

**4460**

**Tool material**

**HSS-E**

**Surface finish**



**Type**

**N**

**Form**

**B**

**Discount group**

**203**

**Cutting direction**

**right-hand**

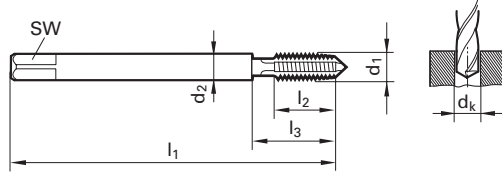

d1	P	Tolerance	d2	SW	dk	l1	l2	l3
	mm		mm		mm	mm	mm	mm
M3	0.50	OH2	4.000	3.20	2.500	100.00	10.00	19.00
M4	0.70	OH2	5.000	4.00	3.300	100.00	12.00	21.00
M5	0.80	OH2	5.500	4.50	4.200	100.00	14.00	25.00
M6	1.00	OH2	6.000	4.50	5.000	150.00	16.00	29.00
M8	1.25	OH2	6.200	5.00	6.800	150.00	17.00	37.00
M10	1.50	OH2	7.000	5.50	8.500	150.00	20.00	41.00
M12	1.75	OH2	8.500	6.50	10.200	150.00	24.00	48.00
M14	2.00	OH2	10.500	8.00	12.000	150.00	26.00	48.00
M16	2.00	OH2	12.500	10.00	14.000	150.00	26.00	52.00
M20	2.50	OH3	15.000	12.00	17.500	200.00	32.00	58.00

Availability



**Guhring no.**

**4462**

**Tool material**

**HSS-E**

**Surface finish**



**Type**

**N R40**

**Form**

**C**

**Discount group**

**203**

**Cutting direction**

**right-hand**



Blind holes

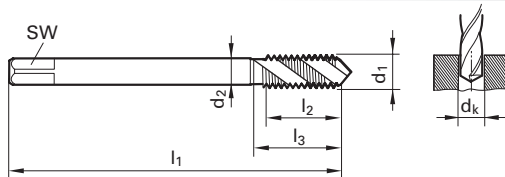

Code no.	d1	P	Tolerance	d2	SW	dk	l1	l2	l3
				mm	mm	mm	mm	mm	mm
2.000	M2	0.40	OH1	3.000	2.50	1.600	100.00	4.50	15.00
2.500	M2.5	0.45	OH1	3.000	2.50	2.050	100.00	5.00	16.00
3.000	M3	0.50	OH2	4.000	3.20	2.500	100.00	6.00	19.00
3.010	M3	0.50	OH2	4.000	3.20	2.500	150.00	6.00	19.00
4.000	M4	0.70	OH2	5.000	4.00	3.300	100.00	7.50	20.00
4.010	M4	0.70	OH2	5.000	4.00	3.300	150.00	7.50	20.00
5.000	M5	0.80	OH2	5.500	4.50	4.200	100.00	8.00	25.00
5.010	M5	0.80	OH2	5.500	4.50	4.200	150.00	8.00	25.00
6.000	M6	1.00	OH2	6.000	4.50	5.000	100.00	11.00	29.00
6.010	M6	1.00	OH2	6.000	4.50	5.000	150.00	11.00	29.00
8.000	M8	1.25	OH2	6.200	5.00	6.800	100.00	14.00	37.00
8.010	M8	1.25	OH2	6.200	5.00	6.800	150.00	14.00	37.00
10.000	M10	1.50	OH2	7.000	5.50	8.500	100.00	16.00	41.00
10.010	M10	1.50	OH2	7.000	5.50	8.500	150.00	16.00	41.00
12.000	M12	1.75	OH2	8.500	6.50	10.200	100.00	18.50	48.00
12.010	M12	1.75	OH2	8.500	6.50	10.200	150.00	18.50	48.00
14.010	M14	2.00	OH2	10.500	8.00	12.000	150.00	20.00	48.00
16.010	M16	2.00	OH2	12.500	10.00	14.000	150.00	20.00	52.00
18.000	M18	2.50	OH3	14.000	11.00	15.500	200.00	25.00	55.00
20.010	M20	2.50	OH3	15.000	12.00	17.500	150.00	27.00	58.00
20.000	M20	2.50	OH3	15.000	12.00	17.500	200.00	25.00	58.00

Availability



## JIS machine taps for ISO metric threads and less rigid machines



Blind holes

Guhring no.

4456

Tool material

HSS-E

Surface finish

○

Type

N R40

Form

C

Discount group

203

Cutting direction

right-hand

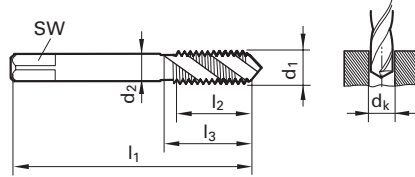

d1	P	Tolerance	d2	SW	dk	l1	l2	l3
	mm		mm		mm	mm	mm	mm
M2	0.40	OH2	3.000	2.50	1.600	40.00	4.50	15.00
M2.5	0.45	OH2	3.000	2.50	2.050	44.00	5.00	16.00
M3	0.50	OH2	4.000	3.20	2.500	46.00	6.00	19.00
M4	0.70	OH2	5.000	4.00	3.300	52.00	7.50	20.00
M5	0.80	OH2	5.500	4.50	4.200	60.00	8.50	24.00
M6	1.00	OH2	6.000	4.50	5.000	62.00	11.00	29.00
M8	1.25	OH2	6.200	5.00	6.800	70.00	14.00	37.00
M10	1.50	OH2	7.000	5.50	8.500	75.00	16.00	41.00
M12	1.75	OH3	8.500	6.50	10.200	82.00	18.50	48.00
M14	2.00	OH3	10.500	8.00	12.000	88.00	20.00	48.00
M16	2.00	OH3	12.500	10.00	14.000	95.00	20.00	52.00
M18	2.50	OH4	14.000	11.00	15.500	100.00	25.00	55.00
M20	2.50	OH4	15.000	12.00	17.500	105.00	25.00	58.00

Availability



## JIS machine taps for ISO metric threads and for hardened steel (42-45 HRC)



Through holes  
and  
blind holes

Guhring no.

4453

Tool material

HSS-E-PM

Surface finish

⊙

Type

H

Form

D

Discount group

203

Cutting direction

right-hand

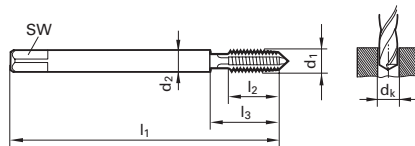

d1	P	Tolerance	d2	SW	dk	l1	l2	l3
	mm		mm		mm	mm	mm	mm
M3	0.50	OH3	4.000	3.20	2.600	46.00	11.00	19.00
M4	0.70	OH3	5.000	4.00	3.400	52.00	13.00	21.00
M5	0.80	OH3	5.500	4.50	4.300	60.00	16.00	24.00
M6	1.00	OH3	6.000	4.50	5.100	62.00	19.00	29.00
M8	1.25	OH3	6.200	5.00	6.900	70.00	22.00	
M10	1.50	OH3	7.000	5.50	8.600	75.00	24.00	
M12	1.75	OH3	8.500	6.50	10.400	82.00	29.00	

Availability



## JIS machine taps for ISO metric threads and cast iron



Guhring no.

4452

Tool material

HSS-E

Surface finish



Type

H

Form

C

Discount group

203

Cutting direction

right-hand

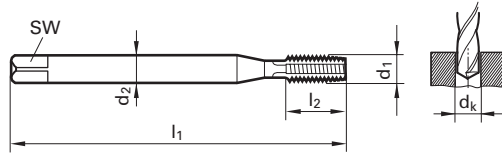

d1	P	Tolerance	d2	SW	dk	l1	l2	l3
	mm		mm		mm	mm	mm	mm
M2	0.40	OH2	3.000	2.50	1.600	40.00	8.00	15.00
M2.5	0.45	OH2	3.000	2.50	2.050	44.00	9.00	16.00
M3	0.50	OH3	4.000	3.20	2.500	46.00	11.00	19.00
M4	0.70	OH3	5.000	4.00	3.300	52.00	13.00	20.00
M5	0.80	OH3	5.500	4.50	4.200	60.00	16.00	24.00
M6	1.00	OH3	6.000	4.50	5.000	62.00	19.00	29.00
M8	1.25	OH4	6.200	5.00	6.800	70.00	22.00	37.00
M10	1.50	OH4	7.000	5.50	8.500	75.00	24.00	41.00
M12	1.75	OH5	8.500	6.50	10.200	82.00	29.00	48.00
M14	2.00	OH5	10.500	8.00	12.000	88.00	30.00	48.00
M16	2.00	OH5	12.500	10.00	14.000	95.00	32.00	52.00
M18	2.50	OH5	14.000	11.00	15.500	100.00	37.00	55.00
M20	2.50	OH5	15.000	12.00	17.500	105.00	37.00	58.00

Availability



## JIS machine taps with IC for ISO metric threads and cast iron



Guhring no.

4448

Tool material

HSS-E-PM

Surface finish



Type

H

Form

C

Discount group

203

Cutting direction

right-hand

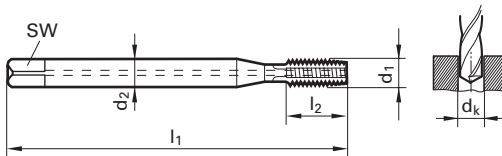

d1	P	Tolerance	d2	SW	dk	l1	l2	l3
	mm		mm		mm	mm	mm	mm
M5	0.80	OH3	5.500	4.50	4.200	60.00	16.00	24.00
M6	1.00	OH3	6.000	4.50	5.000	62.00	19.00	29.00
M8	1.25	OH4	6.200	5.00	6.800	70.00	22.00	37.00
M10	1.50	OH4	7.000	5.50	8.500	75.00	24.00	41.00
M12	1.75	OH5	8.500	6.50	10.200	82.00	29.00	48.00
M14	2.00	OH5	10.500	8.00	12.000	88.00	30.00	48.00
M16	2.00	OH5	12.500	10.00	14.000	95.00	32.00	52.00
M18	2.50	OH5	14.000	11.00	15.500	100.00	37.00	55.00
M20	2.50	OH5	15.000	12.00	17.500	105.00	37.00	58.00

Availability



# JIS machine taps for ISO metric fine threads



**CLASS 1 OH**

**Guhring no.**

**4434**

**Tool material**

**HSS-E**

**Surface finish**

○

**Type**

**N**

**Form**

**B**

**Discount group**

**203**

**Cutting direction**

**right-hand**

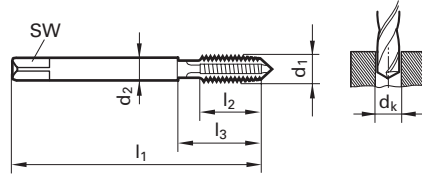

Code no.	d1 X P	Tolerance	d2	SW	dk	l1	l2	l3
			mm		mm	mm	mm	mm
6.004	M6x0.75	OH2	6.000	4.50	5.200	62.00	13.00	30.00
8.005	M8x1	OH2	6.200	5.00	7.000	70.00	16.00	35.00
10.005	M10x1	OH2	7.000	5.50	9.000	70.00	16.00	35.00
10.006	M10x1.25	OH2	7.000	5.50	8.800	75.00	20.00	39.00
12.005	M12x1	OH2	8.500	6.50	11.000	70.00	20.00	40.00
12.006	M12x1.25	OH2	8.500	6.50	10.800	80.00	20.00	40.00
12.007	M12x1.5	OH2	8.500	6.50	10.500	82.00	20.00	40.00
14.007	M14x1.5	OH2	10.500	8.00	12.500	88.00	20.00	40.00
16.007	M16x1.5	OH2	12.500	10.00	14.500	95.00	22.00	44.00
18.007	M18x1.5	OH2	14.000	11.00	16.500	100.00	25.00	55.00
20.007	M20x1.5	OH2	14.000	12.00	18.500	95.00	25.00	44.00

Availability

- 
- 
- 
- 
- 
- 
- 
- 
- 
- 
- 
- 



**CLASS 1 OH**

**Guhring no.**

**4435**

**Tool material**

**HSS-E**

**Surface finish**

Ⓢ

**Type**

**N**

**Form**

**B**

**Discount group**

**203**

**Cutting direction**

**right-hand**

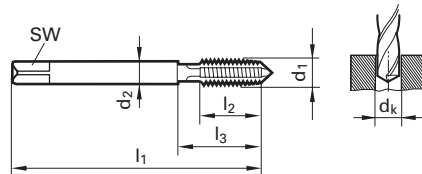

Code no.	d1 X P	Tolerance	d2	SW	dk	l1	l2	l3
			mm		mm	mm	mm	mm
6.004	M6x0.75	OH2	6.000	4.50	5.200	62.00	13.00	30.00
8.005	M8x1	OH2	6.200	5.00	7.000	70.00	16.00	35.00
10.005	M10x1	OH2	7.000	5.50	9.000	70.00	16.00	35.00
10.006	M10x1.25	OH2	7.000	5.50	8.800	75.00	20.00	39.00
12.005	M12x1	OH2	8.500	6.50	11.000	70.00	20.00	40.00
12.006	M12x1.25	OH2	8.500	6.50	10.800	80.00	20.00	40.00
12.007	M12x1.5	OH2	8.500	6.50	10.500	82.00	20.00	40.00
14.007	M14x1.5	OH2	10.500	8.00	12.500	88.00	20.00	40.00
16.007	M16x1.5	OH2	12.500	10.00	14.500	95.00	22.00	44.00
18.007	M18x1.5	OH2	14.000	11.00	16.500	100.00	25.00	55.00
20.007	M20x1.5	OH2	14.000	12.00	18.500	95.00	25.00	44.00

Availability

- 
- 
- 
- 
- 
- 
- 
- 
- 
- 
- 
-



# JIS machine taps for ISO metric fine threads



Guhring no.

4436

Tool material

HSS-E

Surface finish



Type

VA

Form

B

Discount group

203

Cutting direction

right-hand

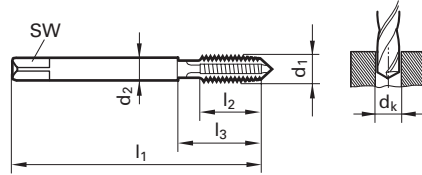

Code no.	d1 x P	Tolerance	d2	SW	dk	l1	l2	l3
			mm		mm	mm	mm	mm
6.004	M6 x0,75	OH2	6.000	4.50	5.200	62.00	13.00	30.00
8.005	M8 x1	OH2	6.200	5.00	7.000	70.00	16.00	35.00
10.005	M10 x1	OH2	7.000	5.50	9.000	70.00	16.00	35.00
10.006	M10 x1,25	OH2	7.000	5.50	8.800	75.00	20.00	39.00
12.005	M12 x1	OH2	8.500	6.50	11.000	70.00	20.00	40.00
12.006	M12 x1,25	OH2	8.500	6.50	10.800	80.00	20.00	40.00
12.007	M12 x1,5	OH2	8.500	6.50	10.500	82.00	20.00	40.00
14.007	M14 x1,5	OH2	10.500	8.00	12.500	88.00	20.00	40.00
16.007	M16 x1,5	OH2	12.500	10.00	14.500	95.00	22.00	44.00
20.007	M20 x1,5	OH2	15.000	12.00	18.500	95.00	25.00	44.00

Availability
●
●
●
●
●
●
●
●
●
●
●



Guhring no.

4437

Tool material

HSS-E

Surface finish



Type

VA

Form

B

Discount group

203

Cutting direction

right-hand

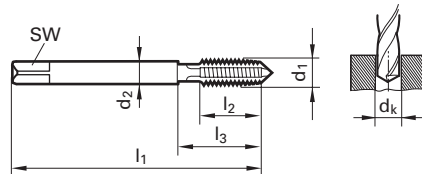

Code no.	d1 X P	Tolerance	d2	SW	dk	l1	l2	l3
			mm		mm	mm	mm	mm
6.004	M6 x0,75	OH2	6.000	4.50	5.200	62.00	13.00	30.00
8.005	M8 x1	OH2	6.200	5.00	7.000	70.00	16.00	35.00
10.005	M10 x1	OH2	7.000	5.50	9.000	70.00	16.00	35.00
10.006	M10 x1,25	OH2	7.000	5.50	8.800	75.00	20.00	39.00
12.005	M12 x1	OH2	8.500	6.50	11.000	70.00	20.00	40.00
12.006	M12 x1,25	OH2	8.500	6.50	10.800	80.00	20.00	40.00
12.007	M12 x1,5	OH2	8.500	6.50	10.500	82.00	20.00	40.00
14.007	M14 x1,5	OH2	10.500	8.00	12.500	88.00	20.00	40.00
16.007	M16 x1,5	OH2	12.500	10.00	14.500	95.00	22.00	44.00
20.007	M20 x1,5	OH2	15.000	12.00	18.500	95.00	25.00	44.00

Availability
●
●
●
●
●
●
●
●
●
●
●

# JIS machine taps for ISO metric fine threads



<b>Guhring no.</b>	<b>4469</b>
<b>Tool material</b>	<b>HSS-E-PM</b>
<b>Surface finish</b>	○
<b>Type</b>	<b>N</b>
<b>Form</b>	<b>B</b>
<b>Discount group</b>	<b>203</b>
<b>Cutting direction</b>	<b>right-hand</b>

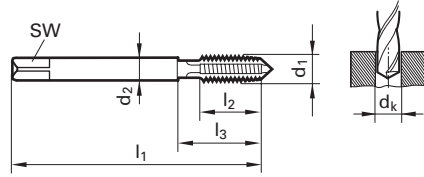

Code no.	d1 X P	Tolerance	d2	SW	dk	l1	l2	l3
			mm		mm	mm	mm	mm
6.004	M6x0.75	OH2	6.000	4.50	5.200	62.00	13.00	30.00
8.005	M8x1	OH3	6.200	5.00	7.000	70.00	16.00	35.00
10.005	M10x1	OH3	7.000	5.50	9.000	70.00	16.00	35.00
10.006	M10x1.25	OH3	7.000	5.50	8.800	75.00	20.00	39.00
12.005	M12x1	OH3	8.500	6.50	11.000	70.00	20.00	40.00
12.006	M12x1.25	OH3	8.500	6.50	10.800	80.00	20.00	40.00
12.007	M12x1.5	OH3	8.500	6.50	10.500	82.00	20.00	40.00
14.007	M14x1.5	OH3	10.500	8.00	12.500	88.00	20.00	40.00
16.007	M16x1.5	OH3	12.500	10.00	14.500	95.00	22.00	44.00
20.007	M20x1.5	OH4	14.000	12.00	18.500	95.00	25.00	44.00

Availability
●
●
●
●
●
●
●
●
●
●
●



<b>Guhring no.</b>	<b>4471</b>
<b>Tool material</b>	<b>HSS-E-PM</b>
<b>Surface finish</b>	Ⓐ
<b>Type</b>	<b>N</b>
<b>Form</b>	<b>B</b>
<b>Discount group</b>	<b>203</b>
<b>Cutting direction</b>	<b>right-hand</b>

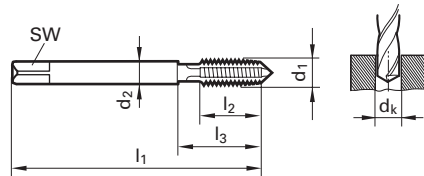

Code no.	d1 X P	Tolerance	d2	SW	dk	l1	l2	l3
			mm		mm	mm	mm	mm
6.004	M6x0.75	OH2	6.000	4.50	5.200	62.00	13.00	30.00
8.005	M8x1	OH3	6.200	5.00	7.000	70.00	16.00	35.00
10.005	M10x1	OH3	7.000	5.50	9.000	70.00	16.00	35.00
10.006	M10x1.25	OH3	7.000	5.50	8.800	75.00	20.00	39.00
12.005	M12x1	OH3	8.500	6.50	11.000	70.00	20.00	40.00
12.006	M12x1.25	OH3	8.500	6.50	10.800	80.00	20.00	40.00
12.007	M12x1.5	OH3	8.500	6.50	10.500	82.00	20.00	40.00
14.007	M14x1.5	OH3	10.500	8.00	12.500	88.00	20.00	40.00
16.007	M16x1.5	OH3	12.500	10.00	14.500	95.00	22.00	44.00
20.007	M20x1.5	OH4	14.000	12.00	18.500	95.00	25.00	44.00

Availability
●
●
●
●
●
●
●
●
●
●
●

# JIS machine taps for ISO metric fine threads



Blind holes

**CLASS 1  
OH**

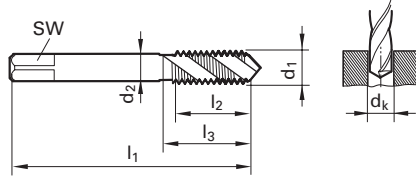

Guhring no.

4438

Tool material

HSS-E

Surface finish

○

Type

N R40

Form

C

Discount group

203

Cutting direction

right-hand

Code no.	d1 X P	Tolerance	d2	SW	dk	l1	l2	l3
			mm		mm	mm	mm	mm
4.003	M4x0.5	OH2	5.000	4.00	3.500	52.00	5.00	20.00
5.003	M5x0.5	OH2	5.500	4.50	4.500	60.00	5.00	25.00
6.003	M6x0.5	OH2	6.000	4.50	5.500	62.00	8.00	30.00
6.004	M6x0.75	OH2	6.000	4.50	5.200	62.00	8.00	30.00
8.004	M8x0.75	OH2	6.200	5.00	7.200	70.00	11.00	35.00
8.005	M8x1	OH2	6.200	5.00	7.000	70.00	11.00	35.00
10.005	M10x1	OH2	7.000	5.50	9.000	70.00	11.00	35.00
10.006	M10x1.25	OH2	7.000	5.50	8.800	75.00	14.00	39.00
12.005	M12x1	OH2	8.500	6.50	11.000	70.00	11.00	40.00
12.006	M12x1.25	OH2	8.500	6.50	10.800	80.00	16.00	40.00
12.007	M12x1.5	OH2	8.500	6.50	10.500	82.00	16.00	40.00
14.007	M14x1.5	OH2	10.500	8.00	12.500	88.00	15.00	40.00
16.007	M16x1.5	OH2	12.500	10.00	14.500	95.00	15.00	44.00
18.007	M18x1.5	OH2	14.000	11.00	16.500	100.00	16.00	55.00
20.007	M20x1.5	OH2	14.000	12.00	18.500	95.00	16.00	44.00
22.007	M22x1.5	OH2	17.000	13.000	20.500	115.00	16.00	63.00

Availability



Blind holes

**CLASS 1  
OH**

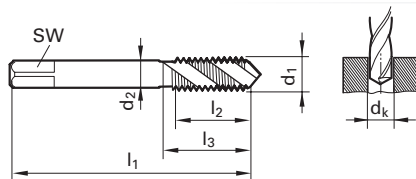

Guhring no.

4439

Tool material

HSS-E

Surface finish

Ⓢ

Type

N R40

Form

C

Discount group

203

Cutting direction

right-hand

Code no.	d1 X P	Tolerance	d2	SW	dk	l1	l2	l3
			mm		mm	mm	mm	mm
6.004	M6x0.75	OH2	6.000	4.50	5.200	62.00	8.00	30.00
8.005	M8x1	OH2	6.200	5.00	7.000	70.00	11.00	35.00
10.005	M10x1	OH2	7.000	5.50	9.000	70.00	11.00	35.00
10.006	M10x1.25	OH2	7.000	5.50	8.800	75.00	14.00	39.00
12.005	M12x1	OH2	8.500	6.50	11.000	70.00	11.00	40.00
12.006	M12x1.25	OH2	8.500	6.50	10.800	80.00	16.00	40.00
12.007	M12x1.5	OH2	8.500	6.50	10.500	82.00	16.00	40.00
14.007	M14x1.5	OH2	10.500	8.00	12.500	88.00	15.00	40.00
16.007	M16x1.5	OH2	12.500	10.00	14.500	95.00	15.00	44.00
18.007	M18x1.5	OH2	14.000	11.00	16.500	100.00	16.00	55.00
20.007	M20x1.5	OH2	14.000	12.00	18.500	95.00	16.00	44.00

Availability



# JIS machine taps for ISO metric fine threads



Blind holes

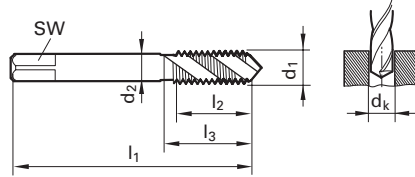

Guhring no.	4440
Tool material	HSS-E
Surface finish	○
Type	VA R40
Form	C
Discount group	203
Cutting direction	right-hand

Code no.	d1 x P	Tolerance	d2	SW	dk	l1	l2	l3
			mm		mm	mm	mm	mm
6.004	M6 x0.75	OH2	6.000	4.50	5.200	62.00	8.00	30.00
8.005	M8 x1	OH2	6.200	5.00	7.000	70.00	11.00	35.00
10.005	M10 x1	OH2	7.000	5.50	9.000	70.00	11.00	35.00
10.006	M10 x1.25	OH2	7.000	5.50	8.800	75.00	14.00	39.00
12.005	M12 x1	OH2	8.500	6.50	11.000	70.00	11.00	40.00
12.006	M12 x1.25	OH2	8.500	6.50	10.800	80.00	16.00	40.00
12.007	M12 x1.5	OH2	8.500	6.50	10.500	82.00	16.00	40.00
14.007	M14 x1.5	OH2	10.500	8.00	12.500	88.00	15.00	40.00
16.007	M16 x1.5	OH2	12.500	10.00	14.500	95.00	15.00	44.00
20.007	M20 x1.5	OH2	15.000	12.00	18.500	95.00	16.00	44.00

Availability



Blind holes

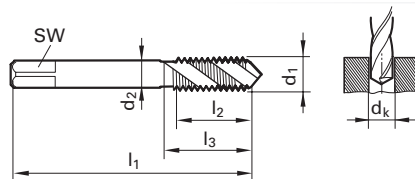

Guhring no.	4441
Tool material	HSS-E
Surface finish	Ⓢ
Type	VA R40
Form	C
Discount group	203
Cutting direction	right-hand

Code no.	d1 x P	Tolerance	d2	SW	dk	l1	l2	l3
			mm		mm	mm	mm	mm
6.004	M6 x0.75	OH2	6.000	4.50	5.200	62.00	8.00	30.00
8.005	M8 x1	OH2	6.200	5.00	7.000	70.00	11.00	35.00
10.005	M10 x1	OH2	7.000	5.50	9.000	70.00	11.00	35.00
10.006	M10 x1.25	OH2	7.000	5.50	8.800	75.00	14.00	39.00
12.005	M12 x1	OH2	8.500	6.50	11.000	70.00	11.00	40.00
12.006	M12 x1.25	OH2	8.500	6.50	10.800	80.00	16.00	40.00
12.007	M12 x1.5	OH2	8.500	6.50	10.500	82.00	16.00	40.00
14.007	M14 x1.5	OH2	10.500	8.00	12.500	88.00	15.00	40.00
16.007	M16 x1.5	OH2	12.500	10.00	14.500	95.00	15.00	44.00
20.007	M20 x1.5	OH2	15.000	12.00	18.500	95.00	16.00	44.00

Availability



# JIS machine taps for ISO metric fine threads



Blind holes

Guhring no.

4467

Tool material

HSS-E-PM

Surface finish



Type

N R40

Form

C

Discount group

203

Cutting direction

right-hand

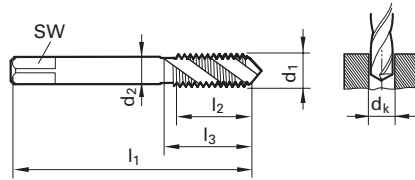

Code no.	d1 X P	Tolerance	d2	SW	dk	l1	l2	l3
			mm		mm	mm	mm	mm
6.004	M6x0.75	OH2	6.000	4.50	5.200	62.00	8.00	30.00
8.005	M8x1	OH3	6.200	5.00	7.000	70.00	11.00	35.00
10.005	M10x1	OH3	7.000	5.50	9.000	70.00	11.00	35.00
10.006	M10x1.25	OH3	7.000	5.50	8.800	75.00	14.00	39.00
12.005	M12x1	OH3	8.500	6.50	11.000	70.00	11.00	40.00
12.006	M12x1.25	OH3	8.500	6.50	10.800	80.00	16.00	40.00
12.007	M12x1.5	OH3	8.500	6.50	10.500	82.00	16.00	40.00
14.007	M14x1.5	OH3	10.500	8.00	12.500	88.00	15.00	40.00
16.007	M16x1.5	OH3	12.500	10.00	14.500	95.00	15.00	44.00
20.007	M20x1.5	OH4	14.000	12.00	18.500	95.00	16.00	44.00

Availability



Guhring no.

4450

Tool material

HSS-E-PM

Surface finish



Type

N R40

Form

C

Discount group

203

Cutting direction

right-hand

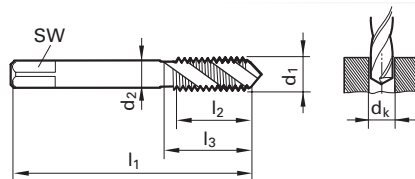

Code no.	d1 X P	Tolerance	d2	SW	dk	l1	l2	l3
			mm		mm	mm	mm	mm
6.004	M6x0.75	OH2	6.000	4.50	5.200	62.00	8.00	30.00
8.005	M8x1	OH3	6.200	5.00	7.000	70.00	11.00	35.00
10.005	M10x1	OH3	7.000	5.50	9.000	70.00	11.00	35.00
10.006	M10x1.25	OH3	7.000	5.50	8.800	75.00	14.00	39.00
12.005	M12x1	OH3	8.500	6.50	11.000	70.00	11.00	40.00
12.006	M12x1.25	OH3	8.500	6.50	10.800	80.00	16.00	40.00
12.007	M12x1.5	OH3	8.500	6.50	10.500	82.00	16.00	40.00
14.007	M14x1.5	OH3	10.500	8.00	12.500	88.00	15.00	40.00
16.007	M16x1.5	OH3	12.500	10.00	14.500	95.00	15.00	44.00
20.007	M20x1.5	OH4	14.000	12.00	18.500	95.00	16.00	44.00

Availability



# JIS machine taps with long shank for ISO metric fine threads



Through holes

Guhring no.

4461

Tool material

HSS-E

Surface finish



Type

N

Form

B

Discount group

203

Cutting direction

right-hand

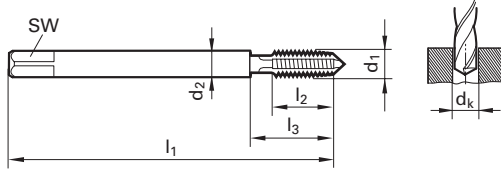

Code no.	d1 X P	Tolerance	d2	SW	dk	l1	l2	l3
			mm		mm	mm	mm	mm
6.004	M6x0.75	OH2	6.000	4.50	5.200	150.00	13.00	30.00
8.005	M8x1	OH2	6.200	5.00	7.000	150.00	16.00	35.00
10.005	M10x1	OH2	7.000	5.50	9.000	150.00	16.00	35.00
10.006	M10x1.25	OH2	7.000	5.50	8.800	150.00	20.00	39.00
12.005	M12x1	OH2	8.500	6.50	11.000	150.00	20.00	40.00
12.006	M12x1.25	OH2	8.500	6.50	10.800	150.00	20.00	40.00
12.007	M12x1.5	OH2	8.500	6.50	10.500	150.00	20.00	40.00
14.007	M14x1.5	OH2	10.500	8.00	12.500	150.00	20.00	40.00
16.007	M16x1.5	OH2	12.500	10.00	14.500	150.00	22.00	44.00
20.007	M20x1.5	OH2	14.000	12.00	18.500	200.00	25.00	44.00

Availability



Blind holes

Guhring no.

4463

Tool material

HSS-E

Surface finish



Type

N R40

Form

C

Discount group

203

Cutting direction

right-hand

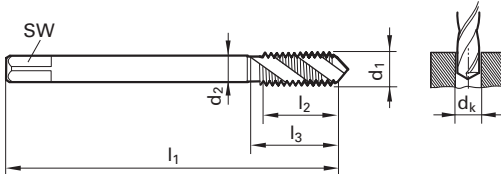

Code no.	d1 X P	Tolerance	d2	SW	dk	l1	l2	l3
			mm		mm	mm	mm	mm
6.004	M6x0.75	OH2	6.000	4.50	5.200	150.00	8.00	30.00
8.005	M8x1	OH2	6.200	5.00	7.000	150.00	11.00	35.00
10.005	M10x1	OH2	7.000	5.50	9.000	150.00	11.00	35.00
10.006	M10x1.25	OH2	7.000	5.50	8.800	150.00	14.00	39.00
12.005	M12x1	OH2	8.500	6.50	11.000	150.00	11.00	40.00
12.006	M12x1.25	OH2	8.500	6.50	10.800	150.00	16.00	40.00
12.007	M12x1.5	OH2	8.500	6.50	10.500	150.00	16.00	40.00
14.007	M14x1.5	OH2	10.500	8.00	12.500	150.00	15.00	40.00
16.007	M16x1.5	OH2	12.500	10.00	14.500	150.00	15.00	44.00
20.007	M20x1.5	OH2	14.000	12.00	18.500	200.00	16.00	44.00

Availability



## JIS machine taps for ISO metric fine threads and less rigid machines



Blind holes

Guhring no.

4458

Tool material

HSS-E

Surface finish



Type

N R40

Form

C

Discount group

203

Cutting direction

right-hand

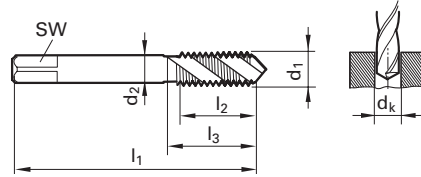

Code no.	d1 X P	Tolerance	d2	SW	dk	l1	l2	l3
			mm		mm	mm	mm	mm
6.004	M6x0.75	OH2	6.000	4.50	5.200	62.00	8.00	30.00
8.005	M8x1	OH3	6.200	5.00	7.000	70.00	11.00	35.00
10.005	M10x1	OH3	7.000	5.50	9.000	70.00	11.00	35.00
10.006	M10x1.25	OH3	7.000	5.50	8.800	75.00	14.00	39.00
12.005	M12x1	OH3	8.500	6.50	11.000	70.00	11.00	40.00
12.006	M12x1.25	OH3	8.500	6.50	10.800	80.00	16.00	40.00
12.007	M12x1.5	OH3	8.500	6.50	10.500	82.00	16.00	40.00
14.007	M14x1.5	OH3	10.500	8.00	12.500	88.00	15.00	40.00
16.007	M16x1.5	OH3	12.500	10.00	14.500	95.00	15.00	44.00
20.007	M20x1.5	OH4	14.000	12.00	18.500	95.00	16.00	44.00

Availability



## JIS machine taps for ISO metric fine threads and for hardened steel (45-55HRC)



Through holes  
and  
blind holes

Guhring no.

4459

Tool material

HSS-E-PM

Surface finish



Type

H

Form

D

Discount group

203

Cutting direction

right-hand

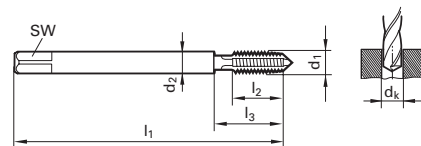

Code no.	d1 X P	Tolerance	d2	SW	dk	l1	l2	l3
			mm		mm	mm	mm	mm
8.005	M8x1	OH3	6.200	5.00	7.100	70.00	19.00	
10.005	M10x1	OH3	7.000	5.50	9.100	75.00	24.00	
10.006	M10x1.25	OH3	7.000	5.50	8.900	75.00	24.00	
12.006	M12x1.25	OH4	8.500	6.50	10.900	82.00	29.00	
12.007	M12x1.5	OH3	8.500	6.50	10.600	82.00	29.00	

Availability



## JIS machine taps for ISO metric fine threads and cast iron



Through holes  
and  
blind holes

Guhring no.

4451

Tool material

HSS-E

Surface finish



Type

H

Form

C

Discount group

203

Cutting direction

right-hand

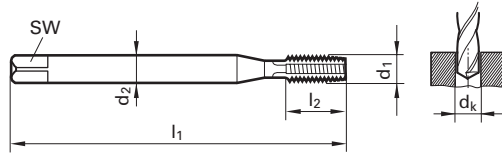

Code no.	d1 X P	Tolerance	d2	SW	dk	l1	l2	l3
			mm		mm	mm	mm	mm
6.004	M6x0.75	OH3	6.000	4.50	5.200	62.00	19.00	30.00
8.005	M8x1	OH3	6.200	5.00	7.000	70.00	22.00	35.00
10.005	M10x1	OH3	7.000	5.50	9.000	70.00	24.00	35.00
10.006	M10x1.25	OH4	7.000	5.50	8.800	75.00	24.00	39.00
12.005	M12x1	OH3	8.500	6.50	11.000	70.00	29.00	40.00
12.006	M12x1.25	OH4	8.500	6.50	10.800	80.00	29.00	40.00
12.007	M12x1.5	OH4	8.500	6.50	10.500	82.00	29.00	40.00
14.007	M14x1.5	OH4	10.500	8.00	12.500	88.00	30.00	40.00
16.007	M16x1.5	OH4	12.500	10.00	14.500	95.00	32.00	44.00
20.007	M20x1.5	OH4	14.000	12.00	18.500	95.00	37.00	44.00

Availability



## JIS machine taps with IC for ISO metric fine threads and cast iron



Through holes  
and  
blind holes

Guhring no.

4472

Tool material

HSS-E-PM

Surface finish



Type

H

Form

C

Discount group

203

Cutting direction

right-hand

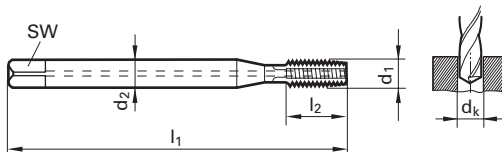

Code no.	d1 X P	Tolerance	d2	SW	dk	l1	l2	l3
			mm		mm	mm	mm	mm
6.004	M6x0.75	OH3	6.000	4.50	5.200	62.00	19.00	30.00
8.005	M8x1	OH3	6.200	5.00	7.000	70.00	22.00	35.00
9.005	M9x1	OH3	7.000	5.50	8.000	70.00	24.00	35.00
10.005	M10x1	OH3	7.000	5.50	9.000	70.00	24.00	35.00
10.006	M10x1.25	OH4	7.000	5.50	8.800	75.00	24.00	39.00
12.005	M12x1	OH3	8.500	6.50	11.000	70.00	29.00	40.00
12.006	M12x1.25	OH4	8.500	6.50	10.800	80.00	29.00	40.00
12.007	M12x1.5	OH4	8.500	6.50	10.500	82.00	29.00	40.00
14.007	M14x1.5	OH4	10.500	8.00	12.500	88.00	30.00	40.00
16.007	M16x1.5	OH4	12.500	10.00	14.500	95.00	32.00	44.00
20.007	M20x1.5	OH4	14.000	12.00	18.500	95.00	37.00	44.00

Availability





# JIS machine taps for UNC threads



Through holes

Guhring no.

4465

Tool material

HSS-E

Surface finish



Type

N

Form

B

Discount group

203

Cutting direction

right-hand

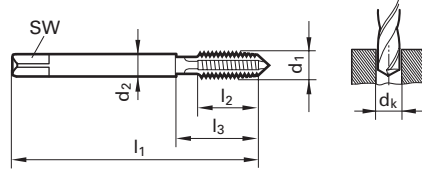

Code no.	d1 X P	Tolerance	d2	SW	dk	l1	l2	l3
			mm		mm	mm	mm	mm
3.505	No.6-32	OH2	4.00	3.20	2.85	48.00	12.00	21.00
4.166	No.8-32	OH2	5.00	4.00	3.50	52.00	12.00	21.00
4.826	No.10-24	OH2	5.50	4.50	3.90	60.00	14.00	25.00
5.486	No.12-24	OH2	5.50	4.50	4.50	60.00	16.00	25.00
6.350	1/4-20	OH3	6.00	4.50	5.10	62.00	16.00	29.00
7.938	5/16-18	OH3	6.10	5.00	6.60	70.00	18.00	37.00
9.525	3/8-16	OH3	7.00	5.50	8.00	75.00	20.00	41.00
11.113	7/16-14	OH3	8.00	6.00	9.40	80.00	22.00	48.00
12.700	1/2-13	OH3	9.00	7.00	10.80	85.00	25.00	48.00
14.288	9/16-12	OH3	10.50	8.00	12.20	90.00	28.00	48.00
15.875	5/8-11	OH3	12.00	9.00	13.50	95.00	30.00	52.00
19.050	3/4-10	OH3	14.00	11.00	16.50	105.00	33.00	58.00
22.225	7/8-9	OH4	17.00	13.00	19.50	115.00	35.00	63.00
25.400	1-8	OH4	20.00	15.00	22.25	125.00	38.00	68.00

Availability



Blind holes

Guhring no.

4454

Tool material

HSS-E

Surface finish



Type

N R40

Form

C

Discount group

203

Cutting direction

right-hand

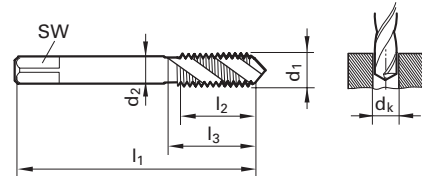

Code no.	d1 X P	Tolerance	d2	SW	dk	l1	l2	l3
			mm		mm	mm	mm	mm
2.184	No.2-56	OH1	3.00	2.50	1.85	42.00	5.00	21.00
2.845	No.4-40	OH1	3.00	2.50	2.35	44.00	7.00	21.00
3.175	No.5-40	OH1	4.00	3.20	2.65	46.00	7.00	21.00
3.505	No.6-32	OH2	4.00	3.20	2.85	48.00	8.00	21.00
4.166	No.8-32	OH2	5.00	4.00	3.50	52.00	8.00	21.00
4.826	No.10-24	OH2	5.50	4.50	3.90	60.00	11.00	25.00
5.486	No.12-24	OH2	5.50	4.50	4.50	60.00	11.00	25.00
6.350	1/4-20	OH3	6.00	4.50	5.10	62.00	13.00	29.00
7.938	5/16-18	OH3	6.10	5.00	6.60	70.00	14.00	37.00
9.525	3/8-16	OH3	7.00	5.50	8.00	75.00	16.00	41.00
11.113	7/16-14	OH3	8.00	6.00	9.40	80.00	18.00	48.00
12.700	1/2-13	OH3	9.00	7.00	10.80	85.00	20.00	48.00
14.288	9/16-12	OH3	10.50	8.00	12.20	90.00	21.00	48.00
15.875	5/8-11	OH3	12.00	9.00	13.50	95.00	24.00	52.00
19.050	3/4-10	OH3	14.00	11.00	16.50	105.00	25.00	58.00
22.225	7/8-9	OH4	17.00	13.00	19.50	115.00	28.00	63.00
25.400	1-8	OH4	20.00	15.00	22.25	125.00	32.00	68.00

Availability



## JIS machine taps for UNF threads



Through holes

Guhring no.

4455

Tool material

HSS-E

Surface finish



Type

N

Form

B

Discount group

203

Cutting direction

right-hand

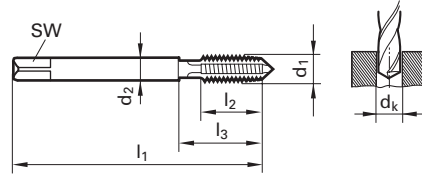

Code no.	d1 X P	Tolerance	d2	SW	dk	l1	l2	l3
			mm		mm	mm	mm	mm
3.505	No.6-40	OH2	4.00	3.20	2.95	48.00	11.00	21.00
4.166	No.8-36	OH2	5.00	4.00	3.50	52.00	12.00	21.00
4.826	No.10-32	OH2	5.50	4.50	4.10	60.00	14.00	25.00
5.486	No.12-28	OH2	5.50	4.50	4.60	60.00	16.00	25.00
6.350	1/4_28	OH2	6.00	4.50	5.50	62.00	16.00	29.00
7.938	5/16-24	OH3	6.10	5.00	6.90	70.00	18.00	37.00
9.525	3/8_24	OH3	7.00	5.50	8.50	75.00	18.00	41.00
11.113	7/16-20	OH3	8.00	6.00	9.90	80.00	22.00	48.00
12.700	1/2-20	OH3	9.00	7.00	11.50	85.00	20.00	48.00
14.288	9/16-18	OH3	10.50	8.00	12.90	90.00	22.00	48.00
15.875	5/8-18	OH3	12.00	9.00	14.50	95.00	22.00	52.00
19.050	3/4-16	OH3	14.00	11.00	17.50	105.00	25.00	58.00
22.225	7/8-14	OH3	17.00	13.00	20.40	115.00	25.00	63.00
25.400	1-12	OH3	20.00	15.00	23.25	125.00	28.00	68.00

Availability



## JIS machine taps for UNF threads



Blind holes

Guhring no.

4457

Tool material

HSS-E

Surface finish



Type

N R40

Form

C

Discount group

203

Cutting direction

right-hand

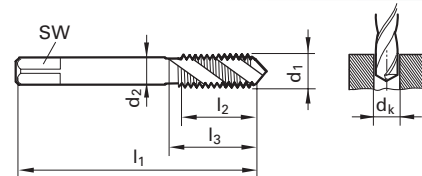

Code no.	d1 X P	Tolerance	d2	SW	dk	l1	l2	l3
			mm		mm	mm	mm	mm
3.505	No.6-40	OH2	4.00	3.20	2.95	48.00	6.50	21.00
4.166	No.8-36	OH2	5.00	4.00	3.50	52.00	7.00	21.00
4.826	No.10-32	OH2	5.50	4.50	4.10	60.00	8.50	25.00
5.486	No.12-28	OH2	5.50	4.50	4.60	60.00	9.00	25.00
6.350	1/4-28	OH2	6.00	4.50	5.50	62.00	9.00	29.00
7.938	5/16-24	OH3	6.10	5.00	6.90	70.00	11.00	37.00
9.525	3/8-24	OH3	7.00	5.50	8.50	75.00	11.00	41.00
11.113	7/16-20	OH3	8.00	6.00	9.90	80.00	13.00	48.00
12.700	1/2-20	OH3	9.00	7.00	11.50	85.00	13.00	48.00
14.288	9/16-18	OH3	10.50	8.00	12.90	90.00	14.00	48.00
15.875	5/8-18	OH3	12.00	9.00	14.50	95.00	15.00	52.00
19.050	3/4-16	OH3	14.00	11.00	17.50	105.00	16.00	58.00
22.225	7/8-14	OH3	17.00	13.00	20.40	115.00	19.00	63.00
25.400	1-12	OH3	20.00	15.00	23.25	125.00	22.00	68.00

Availability



## JIS machine taps for PT threads



Blind holes

Guhring no.

4464

Tool material

HSS-E

Surface finish

○

Type

N R25

Form

C

Discount group

203

Cutting direction

right-hand

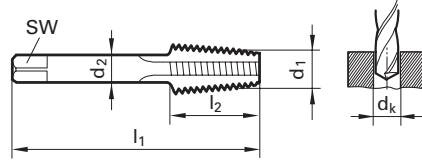

Code no.	d1 X P	Tolerance	d2	SW	dk	l1	l2	l3
			mm		mm	mm	mm	mm
7.723	PT1/16-28	JIS2	8.000	6.00	6.20	55.00	18.00	
9.728	PT1/8-28	JIS2	8.000	6.00	8.20	55.00	19.00	
13.157	PT1/4-19	JIS2	11.00	9.00	10.90	62.00	28.00	
16.662	PT3/8-19	JIS2	14.00	11.00	14.40	65.00	28.00	
20.955	PT1/2-14	JIS2	18.00	14.00	18.00	80.00	35.00	
26.441	PT3/4-14	JIS2	23.00	17.00	23.00	85.00	35.00	
33.249	PT1-11	JIS2	26.00	21.00	29.00	95.00	45.00	

Availability



## JIS fluteless taps w/o oil grooves for ISO metric threads



Through holes  
and  
blind holes

**CLASS 2  
RH**

Guhring no.

1017

Tool material

HSS-E

Surface finish

Ⓢ

Type

N

Form

C

Discount group

203

Cutting direction

right-hand

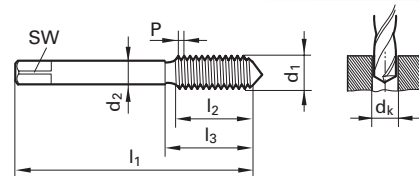

d1	P	Tolerance	d2	SW	dk	l1	l2	l3
	mm		mm		mm	mm	mm	mm
M 1	0.25	RH4	3.000	2.50	0.900	36.00	4.00	
M 1.2	0.25	RH4	3.000	2.50	1.100	36.00	4.80	
M 1.4	0.30	RH4	3.000	2.50	1.250	36.00	5.60	
M 1.6	0.35	RH4	3.000	2.50	1.450	36.00	6.40	
M 1.7	0.35	RH4	3.000	2.50	1.550	36.00	6.80	
M 1.8	0.35	RH4	3.000	2.50	1.650	36.00	7.20	
M 2	0.40	RH4	3.000	2.50	1.850	40.00	8.00	15.00
M 2.5	0.45	RH4	3.000	2.50	2.300	44.00	9.00	16.00
M 3	0.50	RH5	4.000	3.20	2.800	46.00	10.00	19.00
M 4	0.70	RH6	5.000	4.00	3.700	52.00	12.00	20.00
M 5	0.80	RH6	5.500	4.50	4.650	60.00	14.00	24.00
M 6	1.00	RH7	6.000	4.50	5.550	62.00	16.00	29.00
M 8	1.25	RH7	6.200	5.00	7.400	70.00	17.00	37.00
M10	1.50	RH7	7.000	5.50	9.300	75.00	20.00	41.00
M12	1.75	RH8	8.500	6.50	11.200	82.00	24.00	48.00
M14	2.00	RH10	10.500	8.00	13.100	88.00	26.00	48.00
M16	2.00	RH10	12.500	10.00	15.100	95.00	26.00	52.00
M18	2.50	RH11	14.000	11.00	16.900	100.00	30.00	55.00
M20	2.50	RH11	15.000	12.00	18.900	105.00	32.00	58.00

Availability



# JIS fluteless taps with oil grooves for ISO metric threads



Through holes  
and  
blind holes

**CLASS 1  
RH**

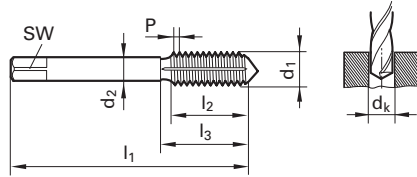

Guhring no.	4442
Tool material	HSS-E
Surface finish	Ⓢ
Type	N
Form	C
Discount group	203
Cutting direction	right-hand

d1	P	Tolerance	d2	SW	dk	l1	l2	l3
	mm		mm		mm	mm	mm	mm
M 4	0.70	RH4	5.000	4.00	3.700	52.00	12.00	20.00
M 5	0.80	RH4	5.500	4.50	4.650	60.00	14.00	24.00
M 6	1.00	RH5	6.000	4.50	5.550	62.00	16.00	29.00
M 8	1.25	RH5	6.200	5.00	7.400	70.00	17.00	37.00
M10	1.50	RH5	7.000	5.50	9.300	75.00	20.00	41.00
M12	1.75	RH5	8.500	6.50	11.200	82.00	24.00	48.00
M16	2.00	RH6	12.500	10.00	15.100	95.00	26.00	52.00
M20	2.50	RH6	15.000	12.00	18.900	105.00	32.00	58.00

Availability

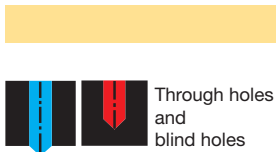

Through holes  
and  
blind holes

**CLASS 2  
RH**

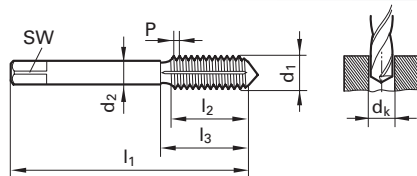

Guhring no.	4443
Tool material	HSS-E
Surface finish	Ⓢ
Type	N
Form	C
Discount group	203
Cutting direction	right-hand

d1	P	Tolerance	d2	SW	dk	l1	l2	l3
	mm		mm		mm	mm	mm	mm
M 4	0.70	RH6	5.000	4.00	3.700	52.00	12.00	20.00
M 5	0.80	RH6	5.500	4.50	4.650	60.00	14.00	24.00
M 6	1.00	RH7	6.000	4.50	5.550	62.00	16.00	29.00
M 8	1.25	RH7	6.200	5.00	7.400	70.00	17.00	37.00
M10	1.50	RH7	7.000	5.50	9.300	75.00	20.00	41.00
M12	1.75	RH8	8.500	6.50	11.200	82.00	24.00	48.00
M16	2.00	RH10	12.500	10.00	15.100	95.00	26.00	52.00
M20	2.50	RH11	15.000	12.00	18.900	105.00	32.00	58.00

Availability



# JIS fluteless taps with oil grooves for ISO metric fine threads



**CLASS 1 RH**

<b>Guhring no.</b>	<b>4444</b>
<b>Tool material</b>	<b>HSS-E</b>
<b>Surface finish</b>	<b>Ⓢ</b>
<b>Type</b>	<b>N</b>
<b>Form</b>	<b>C</b>
<b>Discount group</b>	<b>203</b>
<b>Cutting direction</b>	<b>right-hand</b>

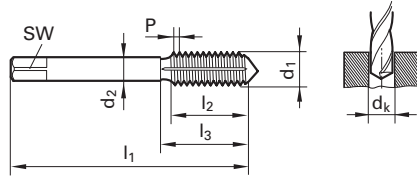

Code no.	d1 x P	Tolerance	d2	SW	dk	l1	l2	l3
			mm		mm	mm	mm	mm
6.004	M6 x0.75	RH4	6.000	4.50	5.650	62.00	13.00	30.00
8.005	M8 x1	RH4	6.200	5.00	7.550	70.00	16.00	35.00
10.005	M10 x1	RH5	7.000	5.50	9.550	70.00	16.00	35.00
10.006	M10 x1.25	RH5	7.000	5.50	9.400	75.00	20.00	39.00
12.005	M12 x1	RH5	8.500	6.50	11.550	70.00	20.00	40.00
12.006	M12 x1.25	RH5	8.500	6.50	11.400	80.00	20.00	40.00
12.007	M12 x1.5	RH5	8.500	6.50	11.300	82.00	20.00	40.00
14.007	M14 x1.5	RH5	10.500	8.00	13.300	88.00	20.00	40.00
16.007	M16 x1.5	RH5	12.500	10.00	15.300	95.00	22.00	44.00
20.007	M20 x1.5	RH6	15.000	12.00	19.300	95.00	25.00	44.00

Availability
●
●
●
●
●
●
●
●
●
●
●



**CLASS 2 RH**

<b>Guhring no.</b>	<b>4445</b>
<b>Tool material</b>	<b>HSS-E</b>
<b>Surface finish</b>	<b>Ⓢ</b>
<b>Type</b>	<b>N</b>
<b>Form</b>	<b>C</b>
<b>Discount group</b>	<b>203</b>
<b>Cutting direction</b>	<b>right-hand</b>

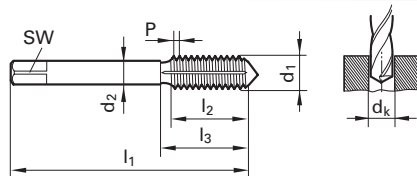

Code no.	d1 x P	Tolerance	d2	SW	dk	l1	l2	l3
			mm		mm	mm	mm	mm
6.004	M6 x0.75	RH6	6.000	4.50	5.650	62.00	13.00	30.00
8.005	M8 x1	RH7	6.200	5.00	7.550	70.00	16.00	35.00
10.005	M10 x1	RH7	7.000	5.50	9.550	70.00	16.00	35.00
10.006	M10 x1.25	RH7	7.000	5.50	9.400	75.00	20.00	39.00
12.005	M12 x1	RH7	8.500	6.50	11.550	70.00	20.00	40.00
12.006	M12 x1.25	RH7	8.500	6.50	11.400	80.00	20.00	40.00
12.007	M12 x1.5	RH7	8.500	6.50	11.300	82.00	20.00	40.00
14.007	M14 x1.5	RH9	10.500	8.00	13.300	88.00	20.00	40.00
16.007	M16 x1.5	RH9	12.500	10.00	15.300	95.00	22.00	44.00
20.007	M20 x1.5	RH10	15.000	12.00	19.300	95.00	25.00	44.00

Availability
●
●
●
●
●
●
●
●
●
●
●

# JIS fluteless taps with oil grooves for ISO metric threads



**CLASS 2 RH**

Guhring no.

4446

Tool material

HSS-E

Surface finish

S

Type

N

Form

C

Discount group

203

Cutting direction

right-hand

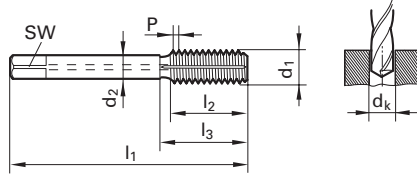

d1	P	Tolerance	d2	SW	dk	l1	l2	l3
	mm		mm		mm	mm	mm	mm
M 5	0.80	RH6	5.500	4.50	4.650	60.00	14.00	24.00
M 6	1.00	RH7	6.000	4.50	5.550	62.00	16.00	29.00
M 8	1.25	RH7	6.200	5.00	7.400	70.00	17.00	37.00
M10	1.50	RH7	7.000	5.50	9.300	75.00	20.00	41.00
M12	1.75	RH8	8.500	6.50	11.200	82.00	24.00	48.00
M16	2.00	RH10	12.500	10.00	15.100	95.00	26.00	52.00
M20	2.50	RH11	15.000	12.00	18.900	105.00	32.00	58.00

Availability

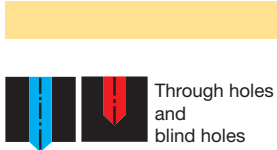

**CLASS 2 RH**

Guhring no.

4447

Tool material

Solid carbide

Surface finish

A

Type

N

Form

C

Discount group

203

Cutting direction

right-hand

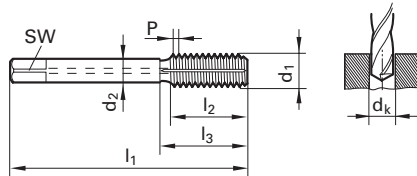

d1	P	Tolerance	d2	SW	dk	l1	l2	l3
	mm		mm		mm	mm	mm	mm
M 5	0.80	RH6	5.500	4.50	4.650	60.00	8.50	24.00
M 6	1.00	RH7	6.000	4.50	5.550	62.00	11.00	29.00
M 8	1.25	RH7	6.200	5.00	7.400	70.00	14.00	37.00
M10	1.50	RH7	7.000	5.50	9.300	75.00	16.00	41.00
M12	1.75	RH8	8.500	6.50	11.200	82.00	18.50	48.00
M16	2.00	RH10	12.500	10.00	15.100	95.00	20.00	52.00
M20	2.50	RH11	15.000	12.00	18.900	105.00	25.00	58.00

Availability



## General information tapping

### Definitions and angles, centres and flute forms

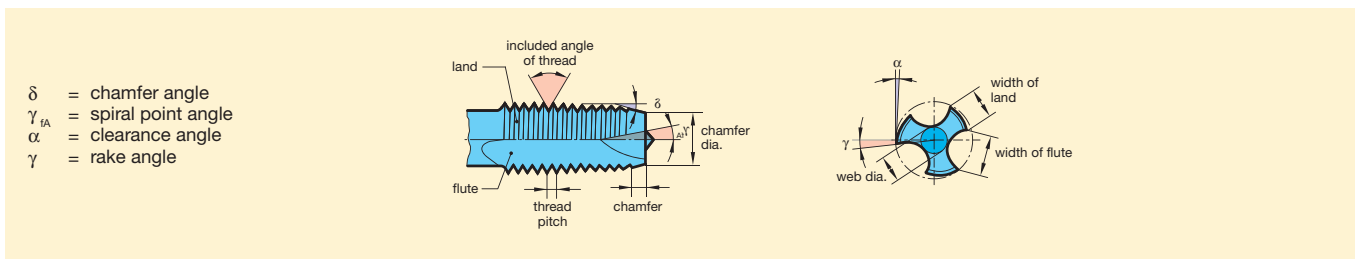
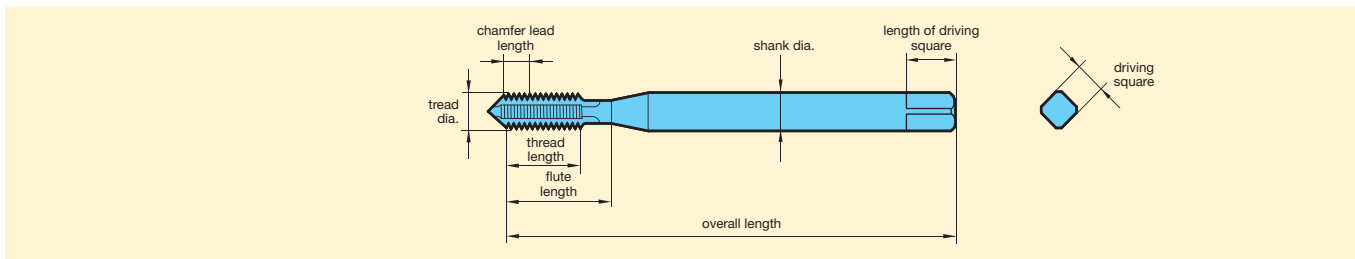

### Flute forms



### Types of centres (standard, to DIN 2197/DIN 2175)

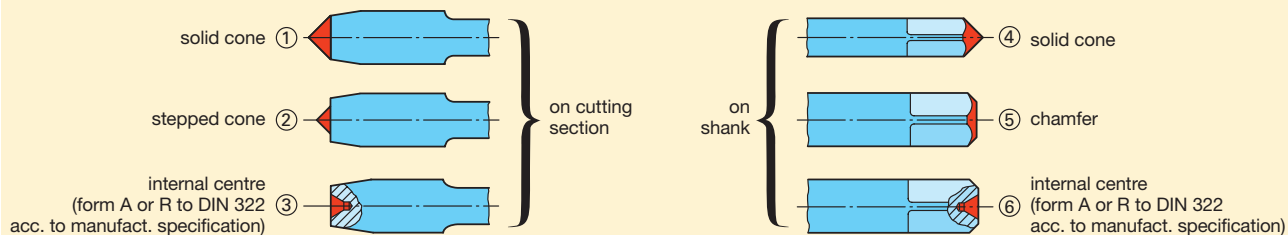

Thread dia. range mm	Centre on cutting section		Centre on shank
	with chamfer forms A, C, D, E	with chamfer form B	
≤ 4.2	①	①	④ ⑤ ⑥
> 4.2 ... 5.6	① ②	①	④ ⑤ ⑥
> 5.6 ... 10.0	① ② ③	① ② ③	④ ⑤ ⑥
> 10.0	③	③	⑥

### Coolant duct geometries

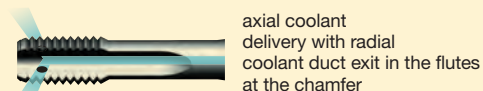
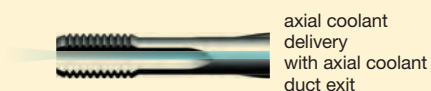

## General information tapping

### Chamfer forms, selection and application

#### Form B

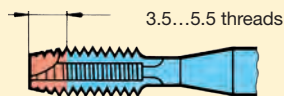

medium, 3.5 - 5.5 threads,  
with spiral point,  
for all through holes  
and deep tapping holes in medium  
and long-chipping materials

#### Form C

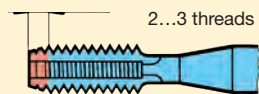

short, 2 - 3 threads  
for blind holes  
and generally for  
aluminium, grey cast iron  
and brass

#### Form D

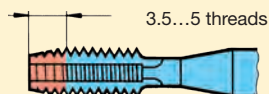

medium, 3.5 - 5 threads  
for short  
through holes

#### Form E

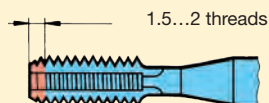

extremely short, 1.5-2 threads,  
for blind holes with  
little run-out depth.

### Why is Guhring increasingly offering Form E taps?

In addition to the conventional Form B and C for machine taps we are increasingly including Form E tools in our standard range. Thus, we are taking into account the increasing demand for taps with which threads can be produced as close as possible to the bottom of the bore when machining blind holes and to produce deepest threads as possible when machining through holes.

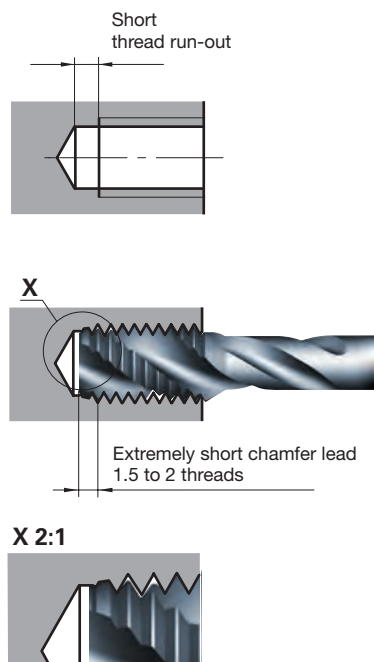

Taps with Form E feature an extremely short chamfer lead with only 1.5 to 2 threads. On modern machines and tapping chucks any inferior guidance of the tool in comparison to Forms B and C with long chamfer lead are eliminated. The run-out of the tap is impossible thanks to the rigid tool clamping. Taps with Form E can provide a significant advantage in the production of very deep reaching, fully tapped threads.



# General information thread forming

Definitions, angles, centres, thread tolerances and fits

## Thread portion

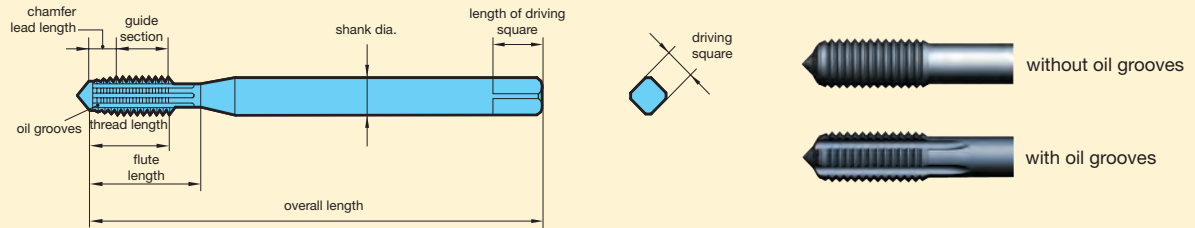

## Cross section of fluteless tap

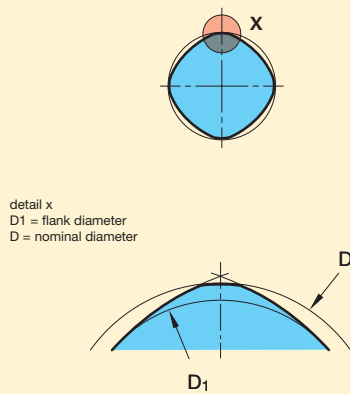

## The principle

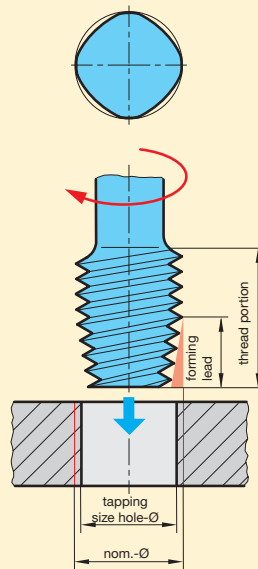

## Types of tapping size hole

with fluteless taps without oil grooves for thread depth  $\leq 1 \times D$



for thread depth  $\geq 1 \times D$



with fluteless taps with oil grooves for all thread depths



# Characteristics of different thread types

Geometry drawing	Standard	Application	Geometry drawing	Standard	Application
<b>M ISO-metric thread</b>			<b>MF ISO-metric fine thread</b>		
	DIN 13-1	General standard thread		DIN 13-2 to DIN 13-11	General fine thread
<b>UNC Unified National Coarse Thread</b>			<b>UNF Unified National Fine Thread</b>		
	ASME B1.1	General UN standard thread		ASME B1.1 ISO-metric trapezoidal thread	General UN fine thread
<b>PT Taper Pipe Thread (identical to Rc and BSPT)</b>					
	JIS B 0203 Japanese Industrial Standard	Internal thread for pipe threads and fittings			

## Tapping size holes for thread cutting

Std. ISO metric threads DIN 13					ISO metric fine threads DIN 13					UNC threads ASME B1.1					UNF threads ASME B1.1				
nom. Ø	pitch P	tapping size hole Ø	core diameter of int. thread 6H		nom. Ø	x pitch P	tapping size hole Ø	core diameter of int. thread 6H		nom. Ø	threads per inch	tapping size hole Ø	core diameter of int. thread 2B		nom. Ø	threads per inch	tapping size hole Ø	core diameter of int. thread 2B	
mm		DIN 336 mm	min. mm	max. mm	mm	mm	DIN 336 mm	min. mm	max. mm			DIN 336 mm	min. mm	max. mm			DIN 336 mm	min. mm	max. mm
M 1	0.25	<b>0.75</b>	0.729	0.785	M 4.0	x 0.50	<b>3.50</b>	3.459	3.599	Nr. 1	- 64	<b>1.55</b>	1.425	1.580	Nr. 1	- 72	<b>1.55</b>	1.473	1.610
M 1.1	0.25	<b>0.85</b>	0.829	0.885	M 4.5	x 0.50	<b>4.00</b>	3.959	4.099	Nr. 2	- 56	<b>1.85</b>	1.694	1.872	Nr. 2	- 64	<b>1.85</b>	1.755	1.910
M 1.2	0.25	<b>0.95</b>	0.929	0.985	M 5.0	x 0.50	<b>4.50</b>	4.459	4.599	Nr. 3	- 48	<b>2.10</b>	1.941	2.146	Nr. 3	- 56	<b>2.15</b>	2.024	2.197
M 1.4	0.30	<b>1.10</b>	1.075	1.142	M 5.5	x 0.50	<b>5.00</b>	4.959	5.099	Nr. 4	- 40	<b>2.35</b>	2.157	2.385	Nr. 4	- 48	<b>2.40</b>	2.271	2.459
M 1.6	0.35	<b>1.25</b>	1.221	1.321	M 6.0	x 0.75	<b>5.20</b>	5.188	5.378	Nr. 5	- 40	<b>2.65</b>	2.487	2.698	Nr. 5	- 44	<b>2.70</b>	2.550	2.741
M 1.8	0.35	<b>1.45</b>	1.421	1.521	M 7.0	x 0.75	<b>6.20</b>	6.188	6.378	Nr. 6	- 32	<b>2.85</b>	2.642	2.896	Nr. 6	- 40	<b>2.95</b>	2.819	3.023
M 2	0.40	<b>1.60</b>	1.567	1.679	M 8.0	x 0.50	<b>7.50</b>	7.459	7.599	Nr. 8	- 32	<b>3.50</b>	3.302	3.531	Nr. 8	- 36	<b>3.50</b>	3.404	3.607
M 2.2	0.45	<b>1.75</b>	1.713	1.838	M 8.0	x 0.75	<b>7.20</b>	7.188	7.378	Nr. 10	- 24	<b>3.90</b>	3.683	3.937	Nr. 10	- 32	<b>4.10</b>	3.962	4.166
M 2.5	0.45	<b>2.05</b>	2.013	2.138	M 8.0	x 1.00	<b>7.00</b>	6.917	7.153	Nr. 12	- 24	<b>4.50</b>	4.343	4.597	Nr. 12	- 28	<b>4.60</b>	4.496	4.724
M 3	0.50	<b>2.50</b>	2.459	2.599	M 9.0	x 0.75	<b>8.20</b>	8.188	8.378	1/4	- 20	<b>5.10</b>	4.978	5.258	1/4	- 28	<b>5.50</b>	5.359	5.588
M 3.5	0.60	<b>2.90</b>	2.850	3.010	M 9.0	x 1.00	<b>8.00</b>	7.917	8.153	5/16	- 18	<b>6.60</b>	6.401	6.731	5/16	- 24	<b>6.90</b>	6.782	7.036
M 4	0.70	<b>3.30</b>	3.242	3.422	M 10	x 0.75	<b>9.20</b>	9.188	9.378	3/8	- 16	<b>8.00</b>	7.798	8.153	3/8	- 24	<b>8.50</b>	8.382	8.636
M 4.5	0.75	<b>3.70</b>	3.688	3.878	M 10	x 1.00	<b>9.00</b>	8.917	9.153	7/16	- 14	<b>9.40</b>	9.144	9.550	7/16	- 20	<b>9.90</b>	9.728	10.033
M 5	0.80	<b>4.20</b>	4.134	4.334	M 10	x 1.25	<b>8.80</b>	8.647	8.912	1/2	- 13	<b>10.80</b>	10.592	11.024	1/2	- 20	<b>11.50</b>	11.328	11.608
M 6	1.00	<b>5.00</b>	4.917	5.153	M 11	x 0.75	<b>10.20</b>	10.188	10.378	9/16	- 12	<b>12.20</b>	11.989	12.446	9/16	- 18	<b>12.90</b>	12.751	13.081
M 7	1.00	<b>6.00</b>	5.917	6.153	M 11	x 1.00	<b>10.00</b>	9.917	10.153	5/8	- 11	<b>13.50</b>	13.386	13.868	5/8	- 18	<b>14.50</b>	14.351	14.681
M 8	1.25	<b>6.80</b>	6.647	6.912	M 12	x 1.00	<b>11.00</b>	10.917	11.153	3/4	- 10	<b>16.50</b>	16.307	16.840	3/4	- 16	<b>17.50</b>	17.323	17.678
M 9	1.25	<b>7.80</b>	7.647	7.912	M 12	x 1.25	<b>10.80</b>	10.647	10.912	7/8	- 9	<b>19.50</b>	19.177	19.761	7/8	- 14	<b>20.40</b>	20.269	20.650
M 10	1.50	<b>8.50</b>	8.376	8.676	M 12	x 1.50	<b>10.50</b>	10.376	10.676	1	- 8	<b>22.25</b>	21.971	22.606	1	- 12	<b>23.25</b>	23.114	23.571
M 11	1.50	<b>9.50</b>	9.376	9.676	M 14	x 1.00	<b>13.00</b>	12.917	13.153						1 1/8	- 12	<b>26.50</b>	26.289	26.746
M 12	1.75	<b>10.20</b>	10.106	10.441	M 14	x 1.25	<b>12.80</b>	12.647	12.912						1 1/4	- 12	<b>29.50</b>	29.464	29.921
M 14	2.00	<b>12.00</b>	11.835	12.210	M 14	x 1.50	<b>12.50</b>	12.376	12.676						1 3/8	- 12	<b>32.75</b>	32.639	33.096
M 16	2.00	<b>14.00</b>	13.835	14.210	M 15	x 1.00	<b>14.00</b>	13.917	14.153						1 1/2	- 12	<b>36.00</b>	35.814	36.271
M 18	2.50	<b>15.50</b>	15.294	15.744	M 15	x 1.50	<b>13.50</b>	13.376	13.676										
M 20	2.50	<b>17.50</b>	17.294	17.744	M 16	x 1.00	<b>15.00</b>	14.917	15.153										
M 22	2.50	<b>19.50</b>	19.294	19.744	M 16	x 1.25	<b>14.80</b>	14.647	14.912										
M 24	3.00	<b>21.00</b>	20.752	21.252	M 16	x 1.50	<b>14.50</b>	14.376	14.676										
M 27	3.00	<b>24.00</b>	23.752	24.252	M 17	x 1.00	<b>16.00</b>	15.917	16.153										
M 30	3.50	<b>26.50</b>	26.211	26.771	M 17	x 1.50	<b>15.50</b>	15.376	15.676										
					M 18	x 1.00	<b>17.00</b>	16.917	17.153										
					M 18	x 1.50	<b>16.50</b>	16.376	16.676										
					M 20	x 1.00	<b>19.00</b>	18.917	19.153										
					M 20	x 1.50	<b>18.50</b>	18.376	18.676										
					M 20	x 2.00	<b>18.00</b>	17.835	18.210										

### PT JIS B 0203 TAPER PIPE THREAD CONE 1:16

nom. Ø	threads per inch	tapping size hole Ø	tapping size hole Ø	cutting depth
		Version A d1	Version B D1	ET mm
PT 1/16	- 28	6.20	6.60	6.20
PT 1/16	- 28	8.20	8.60	6.20
PT 1/16	- 19	10.90	11.50	9.40
PT 1/16	- 19	14.40	15.00	9.70
PT 1/16	- 14	17.90	18.70	12.70
PT 1/16	- 14	23.30	24.20	14.10
PT 1/16	- 11	29.30	30.30	16.20

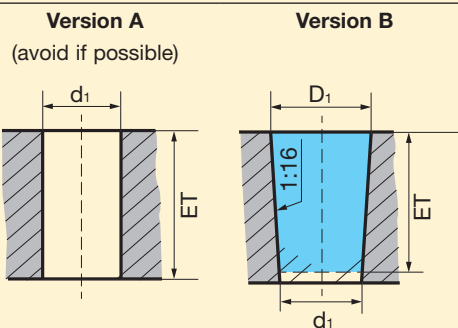

## Tapping size holes for thread forming

Std. ISO metric threads DIN 13						Std. ISO metric fine threads DIN 13							
nom. Ø	pitch P	tapping size hole Ø	tapping size hole Ø		core diameter of int. thread 7H		nom. Ø	x P	tapping size hole Ø	tapping size hole Ø		core diameter of int. thread 7H	
			min.	max.	min.	max.				min.	max.	min.	max.
	mm	mm	mm	mm	mm	mm		mm	mm	mm	mm	mm	mm
M 1	0.25		0.729	0.785			M 6	x 0.75	<b>5.65</b>	5.62	5.70	5.188	5.424
M 1.1	0.25		0.829	0.885			M 7	x 0.75	<b>6.65</b>	6.62	6.70	6.188	6.424
M 1.2	0.25		0.929	0.985			M 8	x 0.75	<b>7.65</b>	7.62	7.70	7.188	7.424
M 1.4	0.30		1.076	1.142			M 8	x 1.00	<b>7.55</b>	7.52	7.62	6.917	7.217
M 1.6	0.35		1.221	1.321			M 9	x 0.75	<b>8.65</b>	8.62	8.70	8.188	8.424
M 1.8	0.35		1.421	1.521			M 9	x 1.00	<b>8.55</b>	8.52	8.62	7.917	8.217
M 2	0.40	<b>1.85</b>	1.84	1.88	1.567	1.679	M 10	x 0.75	<b>9.65</b>	9.62	9.70	9.188	9.424
M 2,2	0.45	<b>2.00</b>	2.01	2.05	1.713	1.838	M 10	x 1.00	<b>9.55</b>	9.52	9.62	8.917	9.217
M 2,5	0.45	<b>2.30</b>	2.28	2.32	2.013	2.138	M 10	x 1.25	<b>9.40</b>	9.36	9.47	8.647	8.982
M 3	0.50	<b>2.80</b>	2.78	2.85	2.459	2.639	M 11	x 0.75	<b>10.65</b>	10.62	10.70	10.188	10.424
M 3,5	0.60	<b>3.25</b>	3.23	3.30	2.850	3.050	M 11	x 1.00	<b>10.55</b>	10.52	10.62	9.917	10.217
M 4	0.70	<b>3.70</b>	3.68	3.76	3.242	3.466	M 12	x 1.00	<b>11.55</b>	11.52	11.62	10.917	11.217
M 4,5	0.75	<b>4.20</b>					M 12	x 1.25	<b>11.40</b>	11.36	11.47	10.647	10.982
M 5	0.80	<b>4.65</b>	4.62	4.71	4.134	4.384	M 12	x 1.50	<b>11.30</b>	11.26	11.38	10.376	10.751
M 6	1.00	<b>5.55</b>	5.52	5.62	4.917	5.217	M 14	x 1.00	<b>13.55</b>	13.52	13.62	12.917	13.217
M 7	1.00	<b>6.55</b>	6.52	6.62	5.917	6.217	M 14	x 1.25	<b>13.40</b>	13.36	13.47	12.647	12.982
M 8	1.25	<b>7.40</b>	7.36	7.47	6.647	6.982	M 14	x 1.50	<b>13.30</b>	13.26	13.38	12.376	12.751
M 9	1.25	<b>8.40</b>	8.36	8.47	7.647	7.982	M 15	x 1.00	<b>14.55</b>	14.52	14.62	13.917	14.217
M 10	1.50	<b>9.30</b>	9.26	9.38	8.376	8.751	M 15	x 1.50	<b>14.30</b>	14.26	14.38	13.376	13.751
M 11	1.50	<b>10.30</b>	10.26	10.38	9.376	9.751	M 16	x 1.00	<b>15.55</b>	15.52	15.62	14.917	15.217
M 12	1.75	<b>11.20</b>	11.15	11.29	10.106	10.531	M 16	x 1.50	<b>15.30</b>	15.26	15.38	14.376	14.751
M 14	2.00	<b>13.10</b>	13.05	13.20	11.835	12.310	M 20	x 1.50	<b>19.30</b>	19.26	19.38	18.376	19.751
M 16	2.00	<b>15.10</b>	15.05	15.20	13.835	14.310							
M 18	2.50	<b>16.90</b>	16.83	17.02	15.294	15.854							
M 20	2.50	<b>18.90</b>	18.83	19.02	17.294	17.854							

### Tapping size hole dia. tolerance zone for thread forming (to DIN 13, section 50)

Due to the tensile strength it is not necessary to adhere to the tapping size hole diameter tolerance class 6H; tolerance class 7H satisfies the requirement that the flank coverage of external and internal threads should not fall below  $0.32 \times P$ . In addition, formed threads generally possess a higher tensile strength in comparison to cut threads thanks to an uninterrupted grain flow and subsequent work hardening.

# OH limits for cutting taps

Pitch  $\leq 0.6$

OH limits

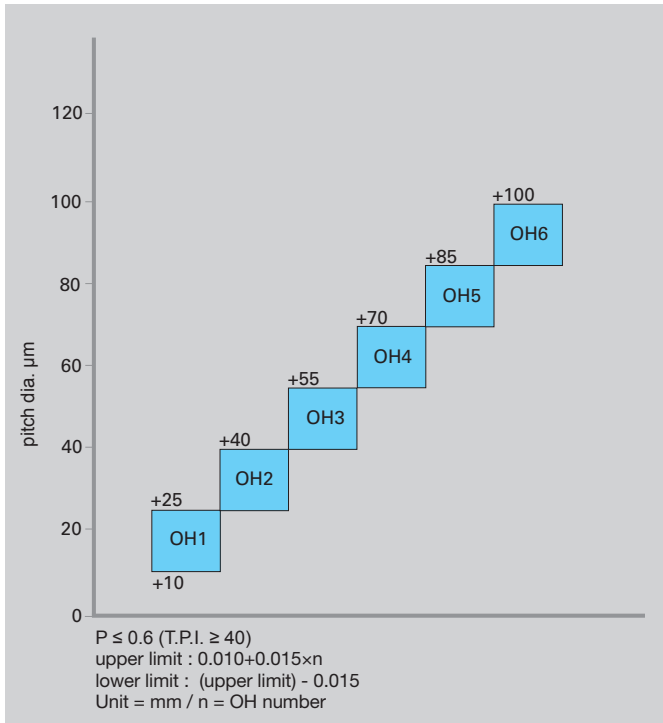

Pitch  $\geq 0.7$

OH limits

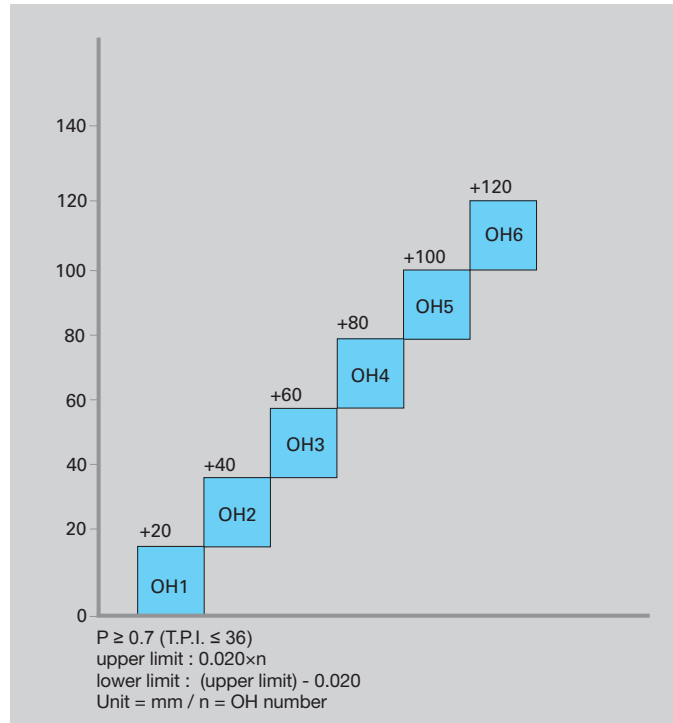

Example M10 (x 1.5)

ISO limits  
OH limits

JIS internal thread  
ISO internal thread

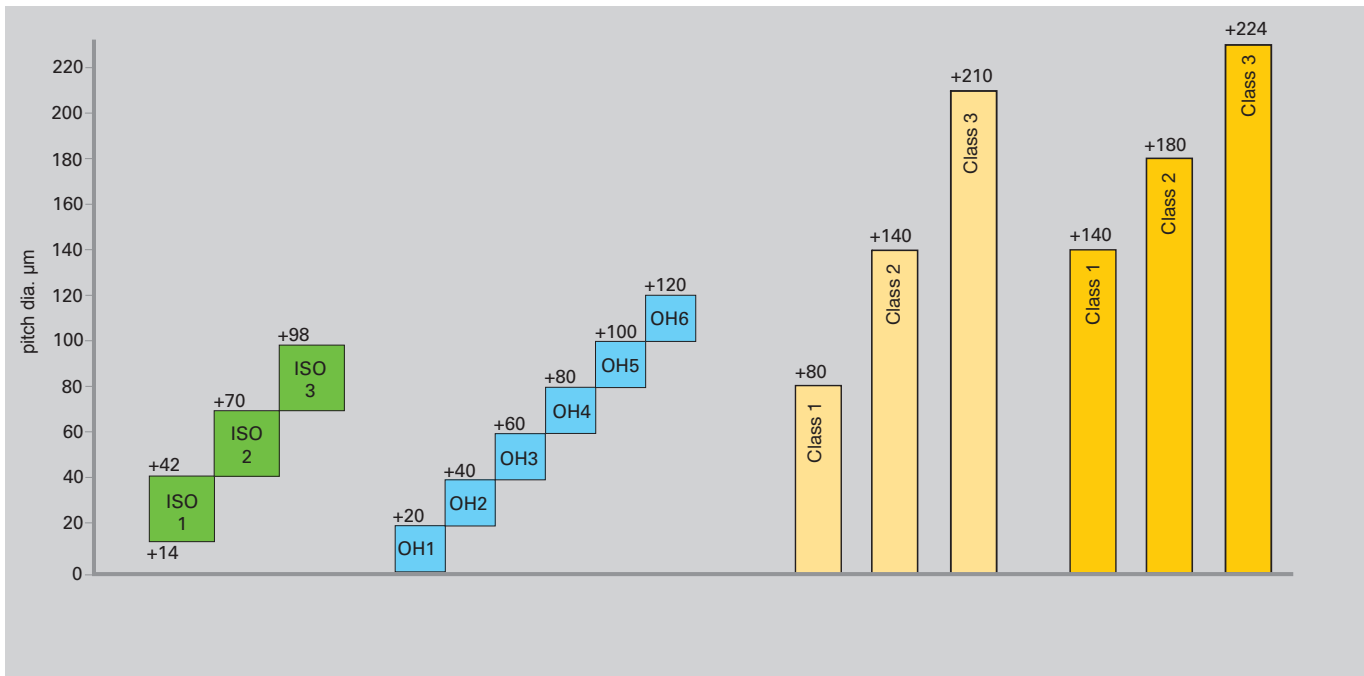

# RH limits for fluteless taps

RH limits

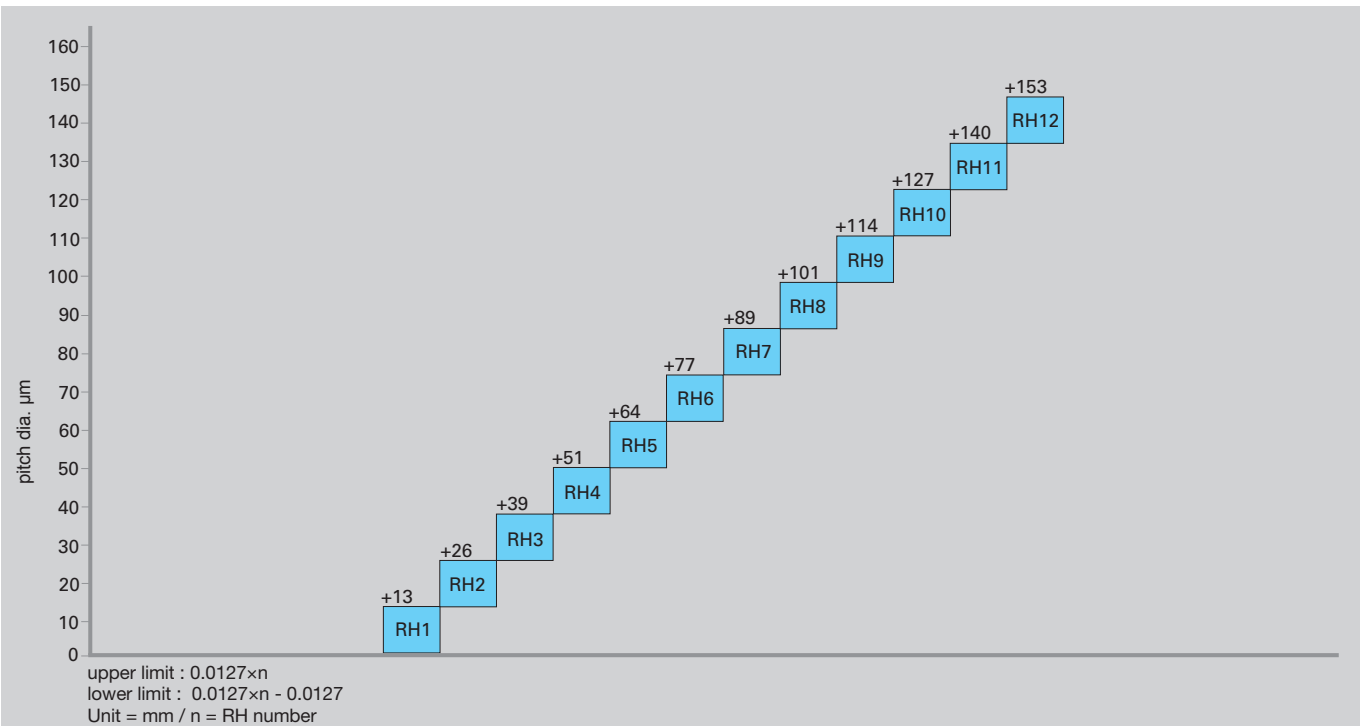

## Example M10 (x 1.5)

ISO limits  
 RH limits

JIS internal thread  
 ISO internal thread

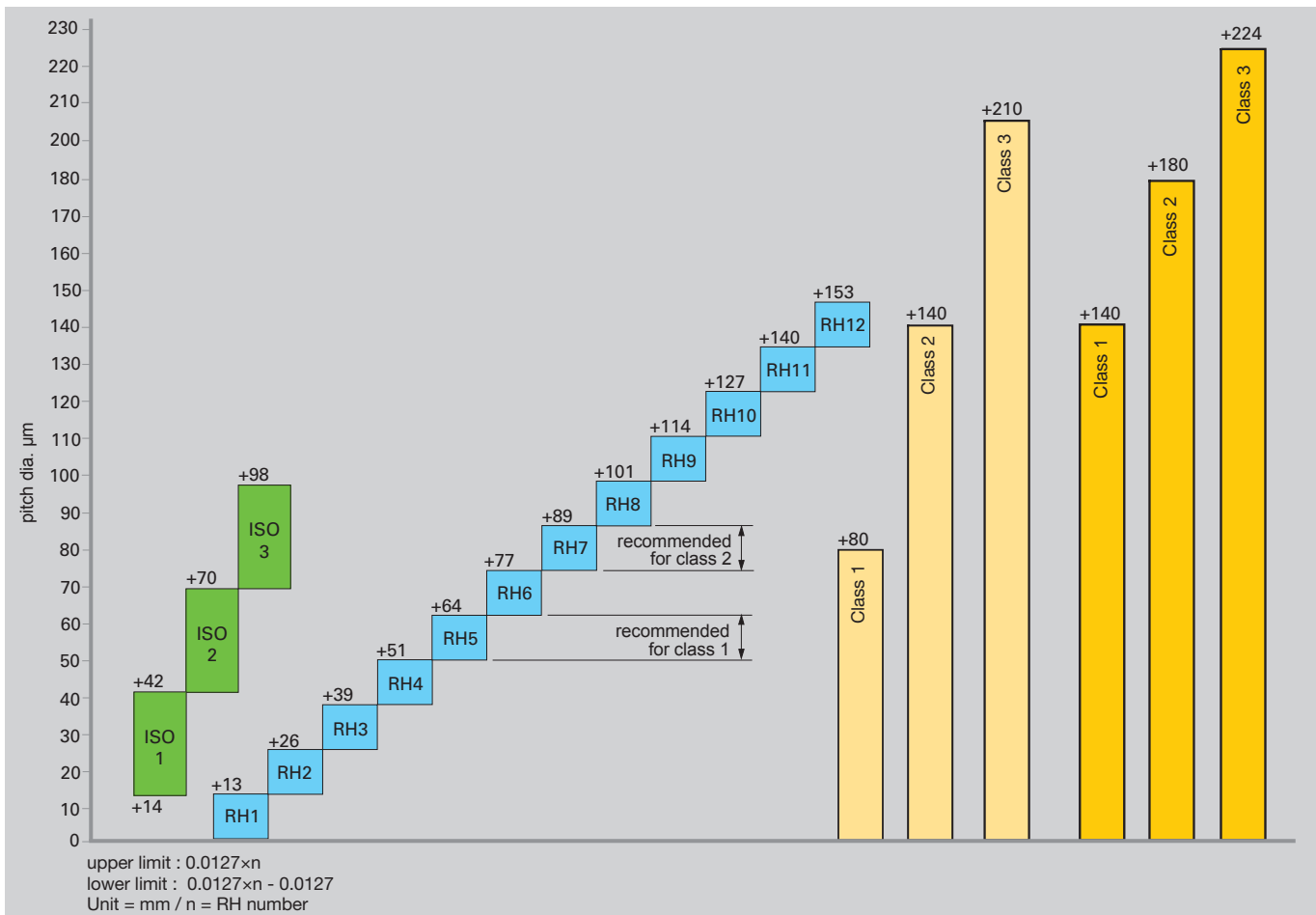

# GÜHROSync

0.3 mm minimal compensation  
for up to 75% reduced axial forces

for internal, peripheral or  
MQL cooling lubrication

high concentricity and  
application speed

elastic polymer elements for effective axial  
and torsion damping of force peaks

quick and simple handling, slim design

long-life metal spring packet with progressive  
force/travel characteristic curve

maximum tool life  
and thread accuracy

## The new **GÜHROSync** tapping chuck

Synchro and hydraulic clamping technology intelligently combined

by **GUHRING**

SAME PRICE  
MORE PERFORMANCE

GÜHROSYNC



by **GUHRING**

UNIVERSELL formvollendete

DRILLING

TAPPING/THREAD MILLING/  
FLUTELESS TAPPING

MILLING

REAMING

PCD



SPECIAL TOOLING  
SOLUTIONS

COUNTERSINKING/  
DE-BURRING

MODULAR TOOLING  
SYSTEMS

TOOL RESTORATION SERVICE

# GUHRING

**Guhring KG**

P.O. Box 100247 • 72423 Albstadt  
Herderstraße 50-54 • 72458 Albstadt

Tel. +49 74 31 17-0  
Fax +49 74 31 17-21279

info@guehring.de  
www.guehring.de

147 149/1551-V-25 • Printed in Germany • 2015

No liability can be accepted for printing errors or technical changes of any kind.  
Our Conditions of Sale and Terms of Payment apply. Available on request.  
**The illustrations show optional equipment.**